

MIMOMesh Wireless MESH/Data Link

Abundant OEM/ODM Module Series

Technical Specification



0.25Watts×2 (7Z020)



0.5Watts×2/1Watts×2 (7Z020)

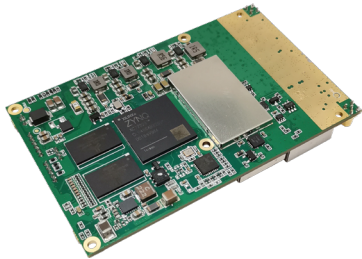

1Watts×2 (7Z020)



2Watts×2 (7Z020)



4Watts×2/5Watts×2
(7Z020)



2Watts×2/4Watts×2/5Watts×2
(7Z030/7Z035)

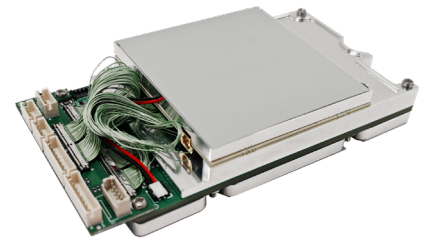

2Watts×2/4Watts×2
(7Z100)



10Watts×2/20Watts×2
(7Z020)

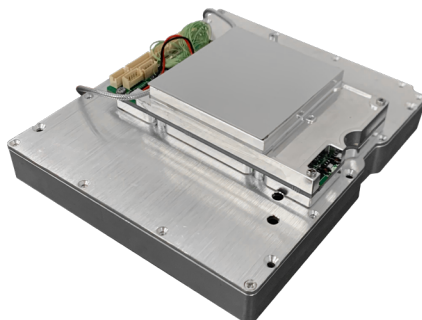

10Watts×2/20Watts×2
(7Z030/7Z035)



10Watts×2/20Watts×2
(7Z100)

1. Specifications

General					
SDR Platform, Waveform	AD936X+FPGA (7Z020, 7Z030, 7Z035, 7Z100), Mobile network MANET+MIMO				
MIMO Technology	Space-time coding, Receive Diversity, TX/RX beamforming, Spatial multiplexing				
Receive Sensitivity	-103dBm@5MHz BW				
Channel Bandwidth	1.25/2.5/5/10/20MHz (7Z020, 7Z030)/40MHz (7Z035)/80MHz (7Z100, 40MHz+40MHz dual antenna frequency transceiver of carrier aggregation), configurable				
Data Rate	1-70Mbps (20MHz BW, 7Z020)/1-130Mbps (20MHz BW, beamforming by 7Z030)/1-252Mbps (40MHz BW)/1-350Mbps (80MHz BW) Adaptive, QoS				
Modulation Mode	TD-COFDM, BPSK/QPSK/16QAM/64QAM/256QAM/1024QAM Adaptive (Fixed setting optional)				
RF Output Power (Support TPC, transmission power control, 1dBm adjustable)	0.25Watts×2; 0.5Watts×2; 1Watts×2; 2Watts×2; 4Watts×2; 5Watts×2; 10Watts×2; 20Watts×2				
Mode	Distributed centerless Point-to-point/Point-to-multipoint/Multipoint-to-multipoint, Layer 2 or 3 of Dynamic routing, Multi-hop relay, Star/Line/Network/Hybrid				
Single Hop Delay	Average 6ms (Unidirectional, 20MHz BW)				
Encryption	DES, AES128/256 (SM4/SNOW3G/ZUC optional, Chip/TF card encryption customized or external encryption machine)				
Anti-Jamming Mode	Manual spectrum scanning channel selection/Full band enhanced intelligent frequency selecting(spectrum awareness)/Full band adaptive frequency hopping FHSS/Roaming mode, Multi-level anti-interference				
Local/Remote Management	Operating frequency, channel bandwidth, network ID, transmit power and other parameter settings, spectrum scanning, real-time display and statistical records of network topology, link field strength signal-to-noise ratio, upload and download traffic, node distance, BD/GPS(GNSS) positioning electronic map, temperature/voltage/jamming Monitoring, software upgrade (remote silence and wake-up optional)				
Others	The startup time is less than 28 seconds, and the network access/update/switchover time is less than 1 second; There is no limit on the user capacity of a single system (256 nodes or more) and the number of hops in Mesh networks (Data 15+ hops, voice 10+ hops, video 8+ hops); The total transmission rate loss for more than three hops is less than 70%; Automatic carrier tracking, adapted to a Doppler frequency deviation of ±6kHz frequency offset, supports mobile communication at speeds above 7200 kilometers per hour (6 Mach, 2000 meters per second)				
Bands (70M-6GHz/Uper C-X-Ku customizable. Same frequency or different frequency of TDD, 2T2R at single band or 1T2R at dual-band)					
BAND	Frequency range	BAND	Frequency range		
VHF/UHF (MHz)	360-450/450-550/570-700/800-950, 225-400/225-678/320-470*	S Band (GHz)	2.0-2.2/2.2-2.4/2.3-2.5/2.5-2.7/2.7-2.9/3.2-3.4/3.4-3.6/3.6-3.8, 1.9-2.7/2.0-2.7/2.1-2.7/2.7-3.6*		
L Band (GHz)	1.0-1.2/1.1-1.3/1.3-1.5/1.5-1.7/1.6-1.8, 1.0-1.5/1.1-1.6/1.2-1.7/1.3-1.8/1.6-2.3/1.7-2.4/1.8-2.5*	C Band (GHz)	4.4-5.0/5.25-5.85, 4.2-5.2/5.5-6.0/6.4-7.2*		
<small>(Note: RF power, Dimensions, Weight is different)</small>					
MIIT (MHz)	336-344/512-592/566-626/606-678/1420-1520/1430-1444				
Environmental					
Operation Temperature	-40°C ~+80°C	Protection Level	IP66 (IP67/IP68 Customized)		
Mechanical		Interface			
Size/Weight	5.1x3.0x0.6cm/11g, 0.25Watts×2	Basic interface	2xIPEX/2xMMCX/2xSMP/2xSMA RF, 1-2xRJ45 Ethernet 100/1000BaseT, RS232, DC input. TTL (UART), SBUS, and Bluetooth 1.2-230.4Kbps, Wi-Fi access point, and BD/GPS (GNSS) are available. Supports transparent transmission over Ethernet and serial ports, and all communication protocols, including MAVLink. Selectable service priority		
	5.8x4.8x1.0cm/27g, 0.5Watts×2/1Watts×2				
	8.7x5.4x1.0cm/40g, 1Watts×2	Network Extension Optional	Public Network Routing/4G LTE, WB-NB integration, Fiber, Satellite		
	8.7x5.4x1.0cm/43g, 2Watts×2				
11.5x5.4x1.3cm/56g, 4Watts×2/5Watts×2	Video Extension Optional	Low Delay HDMI/SDI/CVBS, 4K/2K/1080P/720P/D1			
10.1x5.4x1.9cm/124g, 2Watts×2/4Watts×2/5Watts×2					
10.1x5.4x1.9cm/127g, 2Watts×2/4Watts×2					
12.7x11.0x3.4cm/524g, 10Watts×2/20Watts×2					
12.7x11.0x3.6cm/575g, 10Watts×2/20Watts×2	Power Indicator	Steady green - Powered on			
12.7x11.0x3.6cm/600g, 10Watts×2/20Watts×2					
Installation	4 Mounting Holes	LINK Indicator	Steady red - The network is not connected Blinking red - Starting/not connected to the network Steady green - The network is connected		
				RSSI Indicator	Steady green - The link quality is excellent Steady blue - The link quality is good Steady yellow - The link quality is medium Steady purple - The link quality is slightly worse Steady red - The link quality is poor Off - The link is interrupted
		Power Selection	Power Supply by Main Cable		

2. Hardware Interfaces

2.1 0.25Watts×2

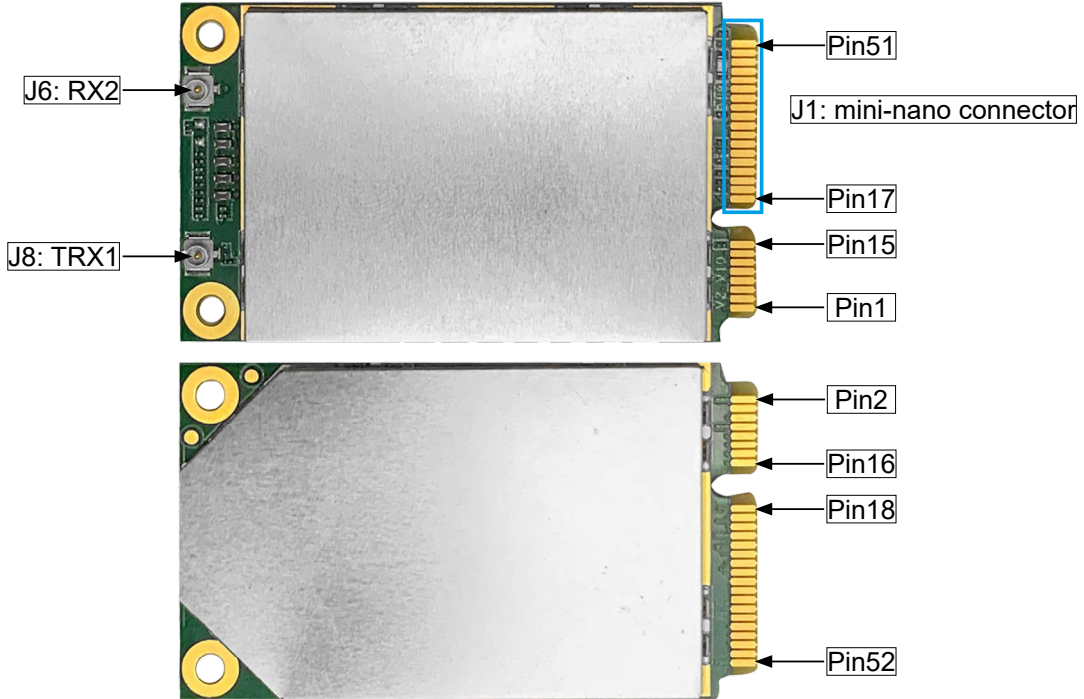

Interface name	Interface function	Connector specification
J1: mini-pcie interface	USB, serial port, LED indication and power supply interface	mini-pcie interface
J6: RF port RX2	RF receiving channel 2	IPEX MHF II
J8: RF port TRX1	RF transmitting and receiving channel 1	IPEX MHF II

2.2 0.5Watts×2/1Watts×2

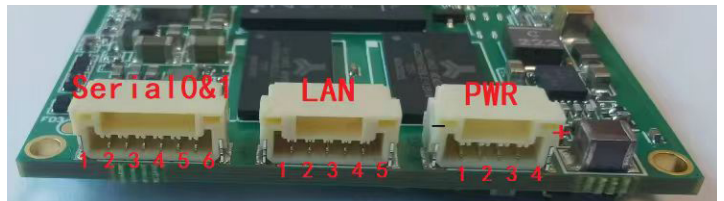
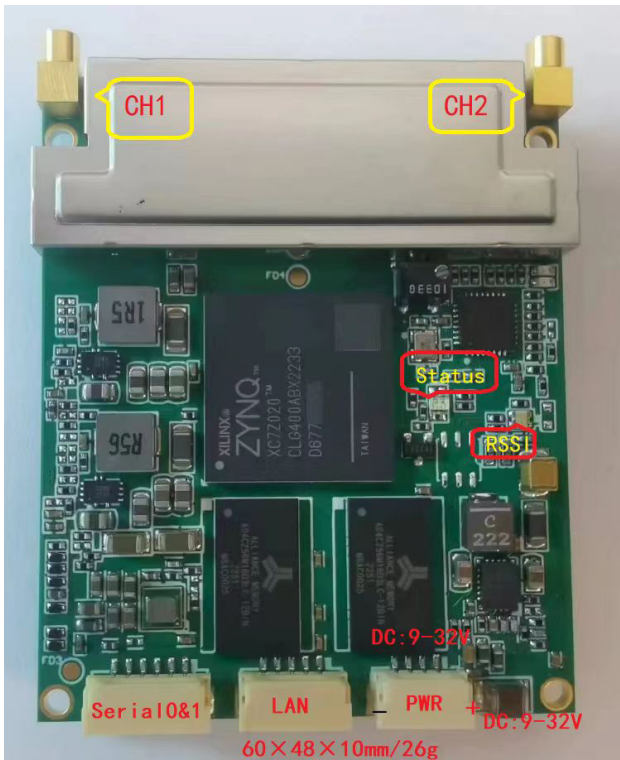

Mavlink/Serial 0&1
(SM06B-GHS)

- Pin1: RS232(Default)/TTL(UART)_GND0&1
- Pin2: RS232(Default)/TTL(UART)_RXD0
- Pin3: RS232(Default)/TTL(UART)_TXD0
- Pin4: RS232(Default)/TTL(UART)_RXD1
- Pin5: RS232(Default)/TTL(UART)_TXD1
- Pin6: 5V OUT

LAN
(SM05B-GHS)

- Pin1: GND
- Pin2: ETH_RX+
- Pin3: ETH_RX-
- Pin4: ETH_TX+
- Pin5: ETH_TX-

PWR
(SM04B-GHS)

- Pin1: GND (-)
- Pin2: GND (-)
- Pin3: VCC (+)
- Pin4: VCC (+)

2.3 1Watts×2/2Watts×2

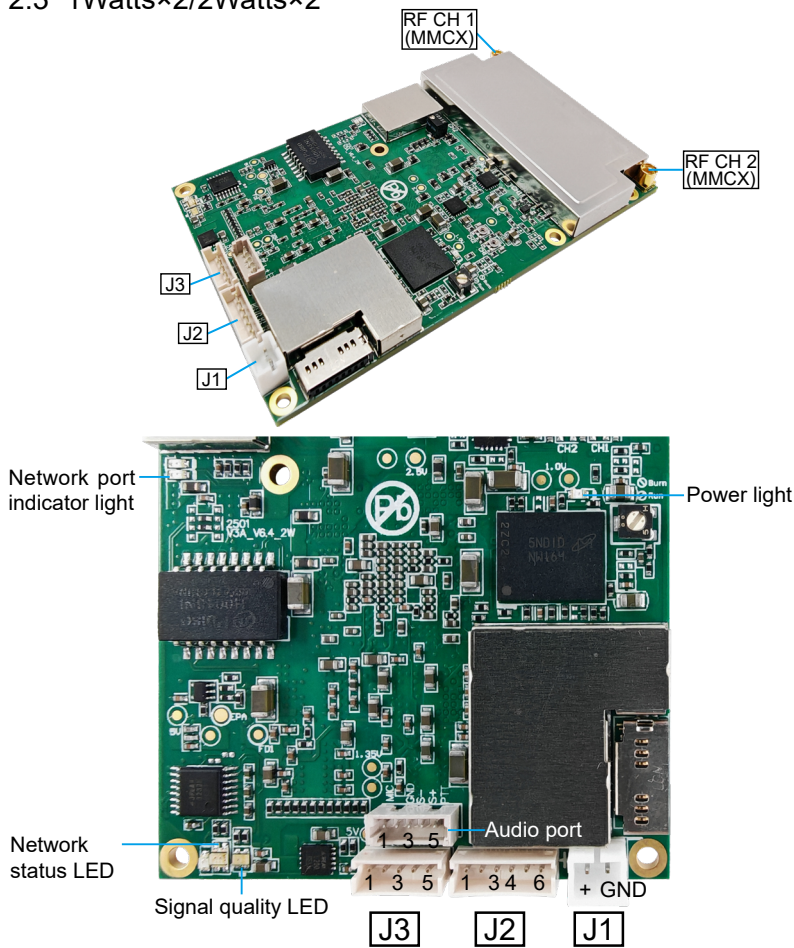

Connector	Pin	Function
J1 Power Supply Port Connector Model: HC-PH-2A	1	GND (-)
	2	12-36V DC(+)
J2 Serial Port	1	RS232/TTL_GND0&1
	2	RS232/TTL_RXD0
	3	RS232/TTL_TXD0
	4	RS232/TTL_RXD1
	5	RS232/TTL_TXD1
J3 Ethernet Port Connector Model: HC-ZH1.5-4A	6	5V OUT
	1	GND
	2	ETH_RX+
	3	ETH_RX-
	4	ETH_TX+
	5	ETH_TX-
Audio Port	1	MIC
	2	AUDIO_GND
	3	SPK+
	4	SPK-
	5	PTT

2.4 4Watts×2/5Watts×2

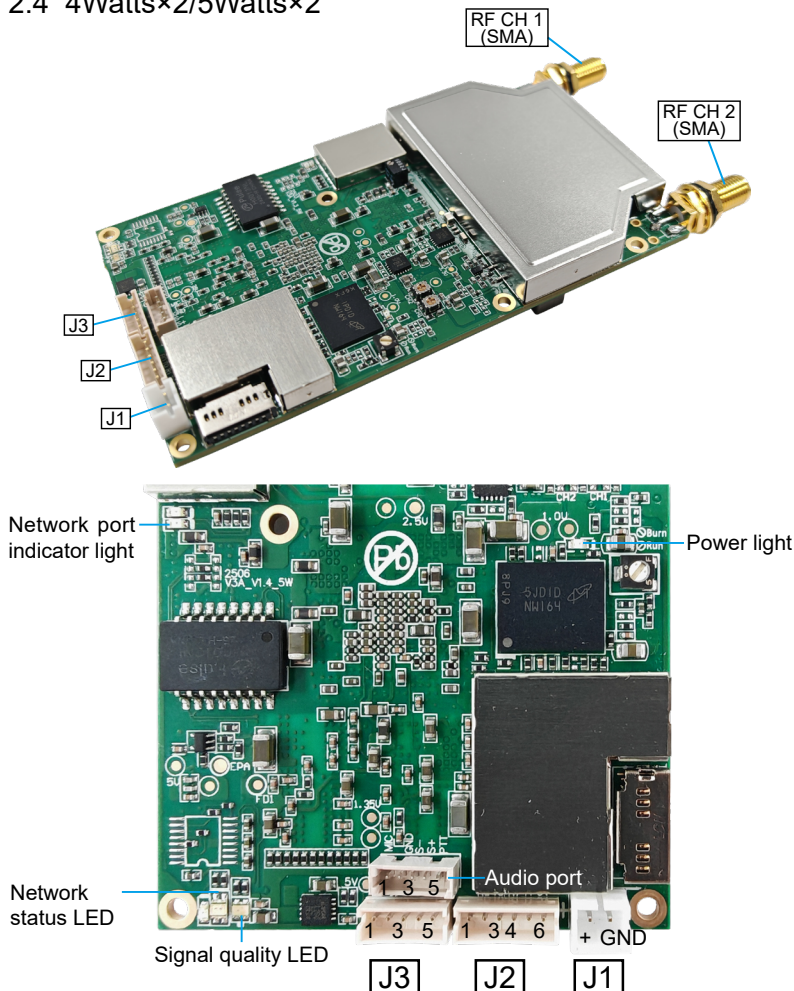

Connector	Pin	Function
J1 Power Supply Port Connector Model: HC-PH-2A	1	GND (-)
	2	12-36V DC (+)
J2 Serial Port	1	RS232/TTL_GND0&1
	2	RS232/TTL_RXD0
	3	RS232/TTL_TXD0
	4	RS232/TTL_RXD1
	5	RS232/TTL_TXD1
J3 Ethernet Port Connector Model: HC-ZH1.5-4A	6	5V OUT
	1	GND
	2	ETH_RX+
	3	ETH_RX-
	4	ETH_TX+
	5	ETH_TX-
Audio Port	1	MIC
	2	AUDIO_GND
	3	SPK+
	4	SPK-
	5	PTT

2.5 2Watts×2/4Watts×2/5Watts×2 (7Z030/7Z035)

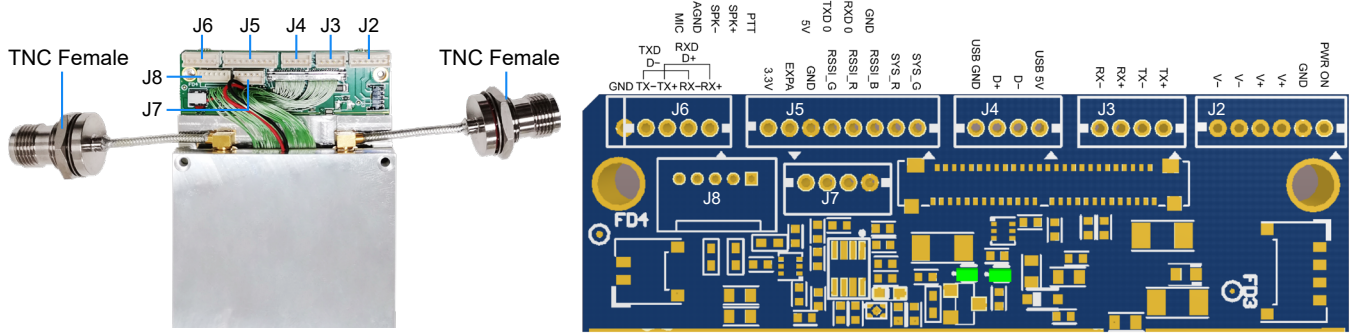

The OEM module provides the J2-J7 connector cable by default. The connector cable length is 23cm. See the following table for port definitions and cable colors:

Connector	Pin	Function	Thread Color	Illustrate
J2 Power Supply Port Connector Model: ZHR-6, 1.5mm	1	Power Switch	yellow	1-2 short circuit, power supply cut off 1-2 disconnected, power supply
	2	GND	black	
	3	VCC(+)	red	External power input
	4	VCC(+)	red	
	5	GND(-)	black	
	6	GND(-)	black	
J3 Ethernet Port Connector Model: ZHR-4, 1.5mm	1	RJ45_Pin 6	yellow	Module network port output
	2	RJ45_Pin 3	green	
	3	RJ45_Pin 2	black	
	4	RJ45_Pin 1	red	
J4 USB Port Connector Model: ZHR-4, 1.5mm	1	USB_5V	red	USB port (USB 2.0 host mode)
	2	USB_D-	green	
	3	USB_D+	White	
	4	USB_GND	black	
J5 External Output Port Connector Model: ZHR-8, 1.5mm	1	LINK light - green	red	1. The LED control line turns on when the output is low. The RSSI uses a three-color LED, with the mixed color representing the RSSI strength 2. The driver resistor is already set on the board. If using an external LED, simply connect the 3.3V LED to the LED
	2	LINK light - red	green	
	3	RSSI light -red	blue	
	4	RSSI light - green	red	
	5	RSSI light -blue	green	
	6	GND	black	External amplifier control, reserved, do not use
	7	EXPA	grey	
	8	LED_3.3V	red	
J6 Serial Port (RS422/485) Connector Model: ZHR-5, 1.5mm	1	RS422_RX+	blue	Pin numbers from left to right: 54321 RS422 interface: GND, TX-, TX+, RX-, RX+ RS485 interface: TX-, RX- parallel to D- TX+, RX+ parallel to D+
	2	RS422_RX-	White	
	3	RS422_TX+	green	
	4	RS422_TX-	yellow	
	5	GND	black	
J7 Serial Port (RS232) Connector Model: ZHR-4, 1.5mm	1	NC	black	RS232 interface
	2	RS232_TXD	green	
	3	RS232_RXD	yellow	
	4	RS232_GND	black	
J8 PTT Port Connector Model: ZHR-5, 1.5mm	1	MIC_IN	blue	
	2	AUDIO_GND	green	
	3	SPK-	yellow	
	4	SPK+	black	
	5	PTT	red	

Note: When the on-board indicators are not used, please remove the indicators D1 and D2.

2.6 2Watts×2/4Watts×2 (7Z100)

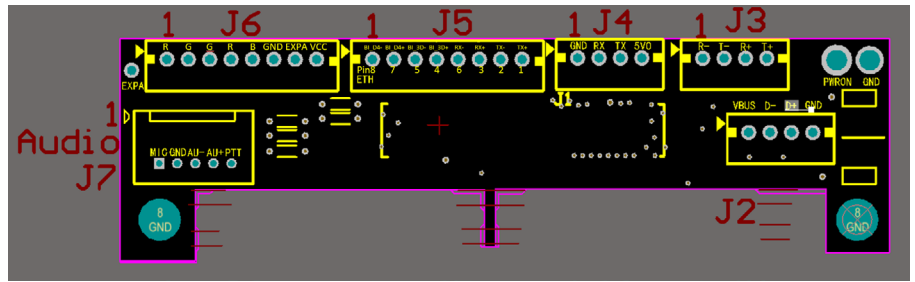
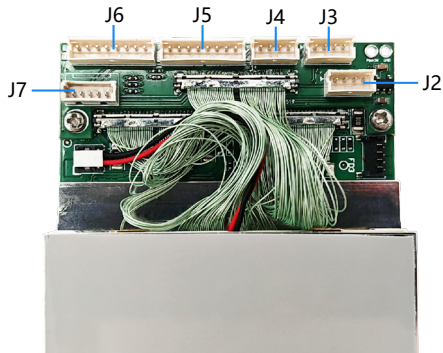

The OEM module provides the J4-J7 connector cable by default. The connector cable length is 23cm. See the following table for port definitions and cable colors:

Connector	Pin	Function	Thread Color	Illustrate
J2 USB Port Connector Model: ZHR-4, 1.5mm	1	USB_5V	red	USB port (USB 2.0 host mode)
	2	USB_D-	yellow	
	3	USB_D+	green	
	4	USB_GND	black	
J3 Serial Port (RS422/485) Connector Model: ZHR-4, 1.5mm	1	RS422_RX-	yellow	RS422 interface: TX-, TX+, RX-, RX+ RS485 interface: TX-, RX- parallel to D- TX+, RX+ parallel to D+
	2	RS422_TX-	green	
	3	RS422_RX+	black	
	4	RS422_TX+	red	
J4 Serial Port (RS232) Connector Model: ZHR-4, 1.5mm	1	RS232_GND	black	RS232 port 5V OUT for external GPS/GALILEO
	2	RS232_RXD	green	
	3	RS232_TXD	yellow	
	4	5V OUT	black	
J5 Ethernet Port (Gigabit) Connector Model: ZHR-8, 1.5mm	1	RJ45_Pin 8	red	Pair 1: Pin 1 is TX+, Pin 2 is TX- Pair 2: Pin 3 is RX+, Pin 6 is RX- Pair 3: Pin 4 is BI_D3+, Pin 5 is BI_D3- Pair 4: Pin 7 is BI_D4+, Pin 8 is BI_D4-
	2	RJ45_Pin 7	black	
	3	RJ45_Pin 5	green	
	4	RJ45_Pin 4	yellow	
	5	RJ45_Pin 6	red	
	6	RJ45_Pin 3	black	
	7	RJ45_Pin 2	green	
	8	RJ45_Pin 1	yellow	
J6 External Output Port Connector Model: ZHR-8, 1.5mm	1	LINK light - red	red	1. LED control line, lights up when output L; RSSI uses three-color LED, and mixed colors represent RSSI strength 2. The driving resistor is already set on the board. If you use an external light-emitting diode, you can directly connect the 3.3V LED and the light-emitting diode External amplifier control, reserved, do not use
	2	LINK light - green	green	
	3	RSSI light - green	blue	
	4	RSSI light -red	red	
	5	RSSI light -blue	green	
	6	GND	black	
	7	EXPA	grey	
	8	LED_3.3V	red	
J7 PTT Port Connector Model: ZHR-5, 1.5mm	1	MIC	red	
	2	AUDIO_GND	black	
	3	SPK-	yellow	
	4	SPK+	green	
	5	PTT	blue	

2.7 10Watts×2/20Watts×2



Connector	Pin	Function
J1 Power Supply Port Connector Model: HC-PH-2A	1	GND (-)
	2	18-32V DC (+)
J2 Serial Port	1	RS232/TTL_GND0&1
	2	RS232/TTL_RXD0
	3	RS232/TTL_TXD0
	4	RS232/TTL_RXD1
	5	RS232/TTL_TXD1
	6	5V OUT
J3 Ethernet Port Connector Model: HC-ZH1.5-4A	1	GND
	2	ETH_RX+
	3	ETH_RX-
	4	ETH_TX+
	5	ETH_TX-

2.8 10Watts×2/20Watts×2

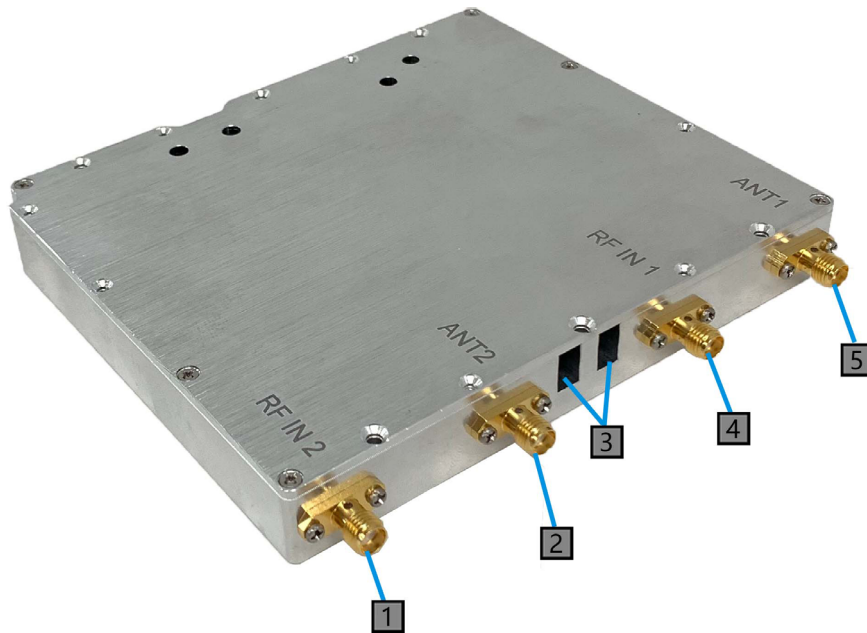

1 A1 IN

2 A1 OUT

3 Powered

4 A2 IN

5 A2 OUT

3. Dimension Figure

3.1 0.25Watts×2

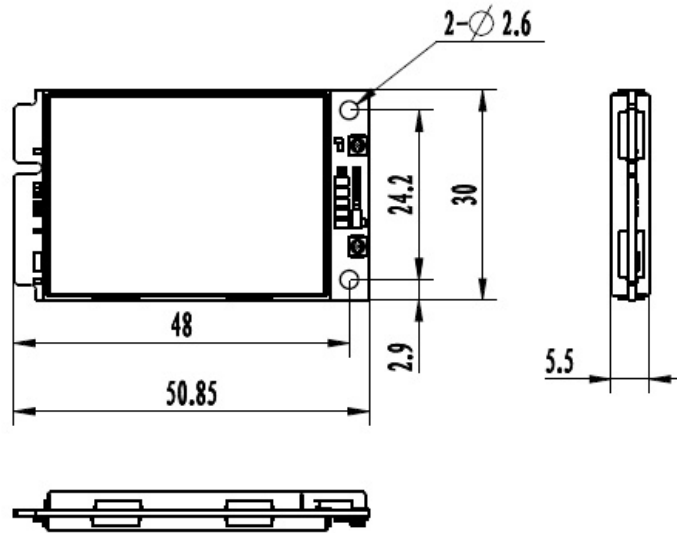

3.2 0.5Watts×2/1Watts×2

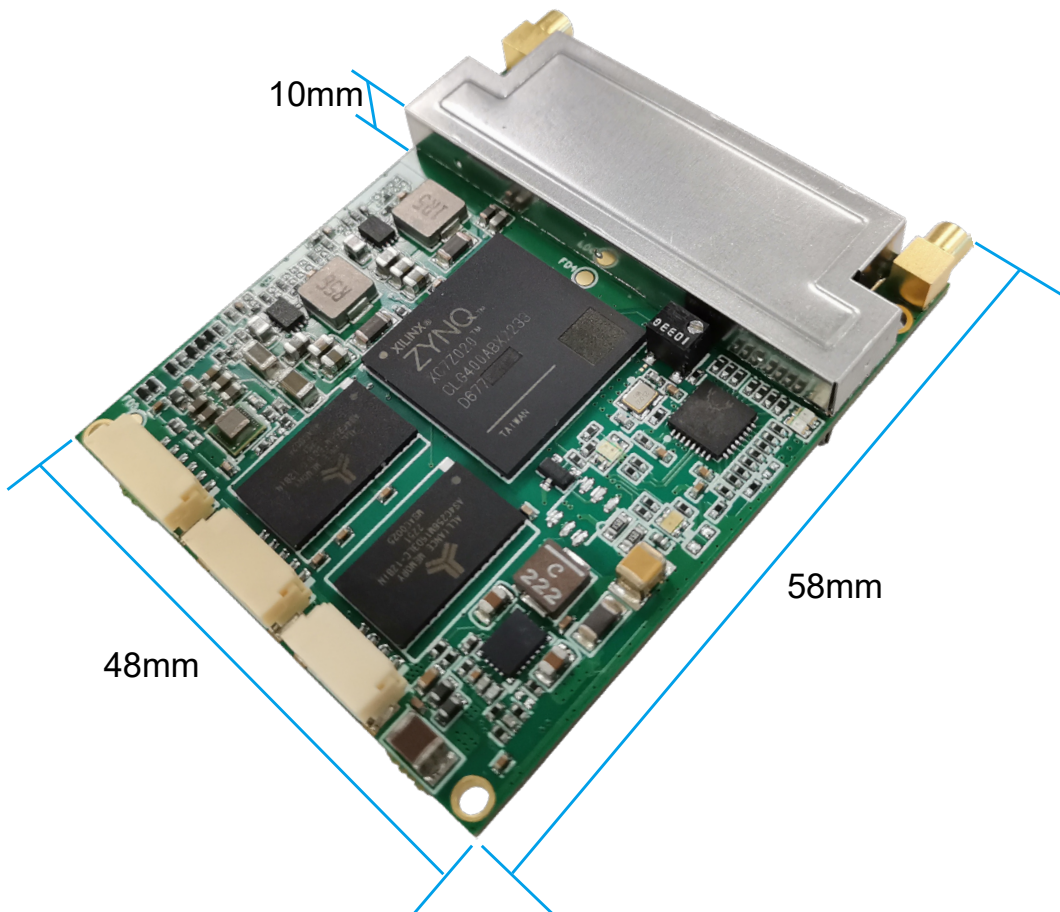

3.3 1Watts×2/2Watts×2

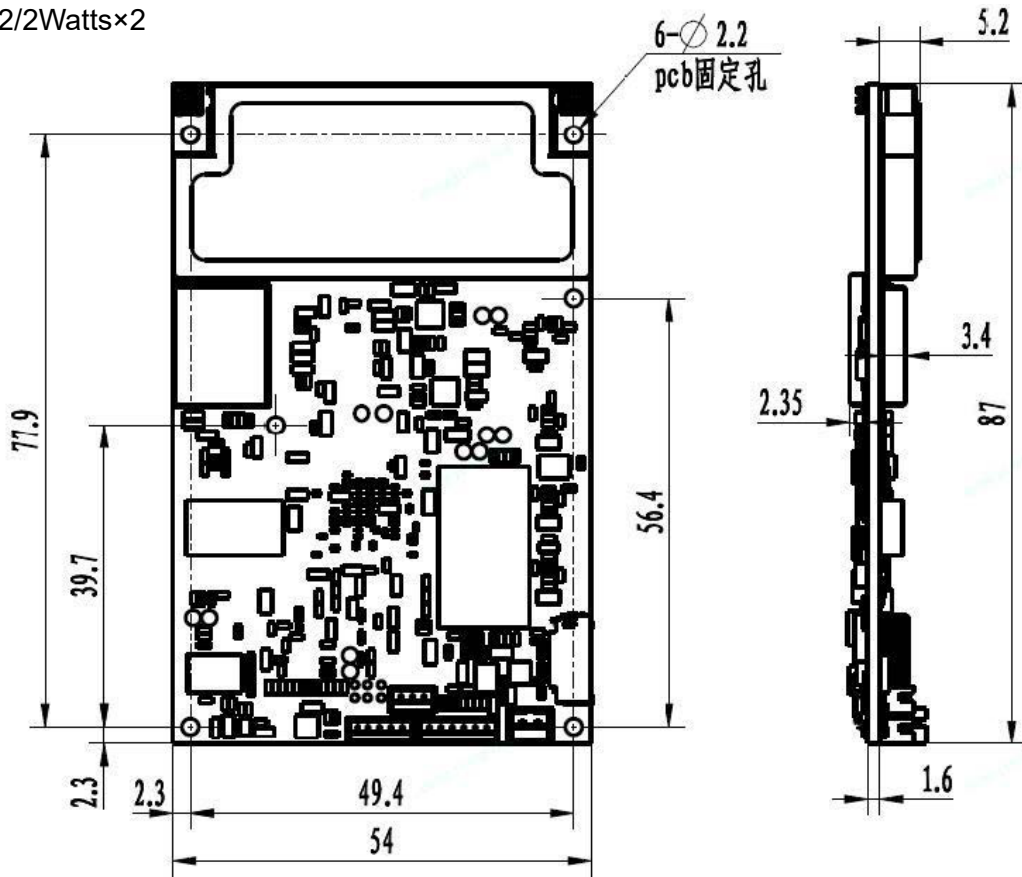

3.4 4Watts×2/5Watts×2



3.5 2Watts×2/4Watts×2/5Watts×2 (7Z035/7Z100)

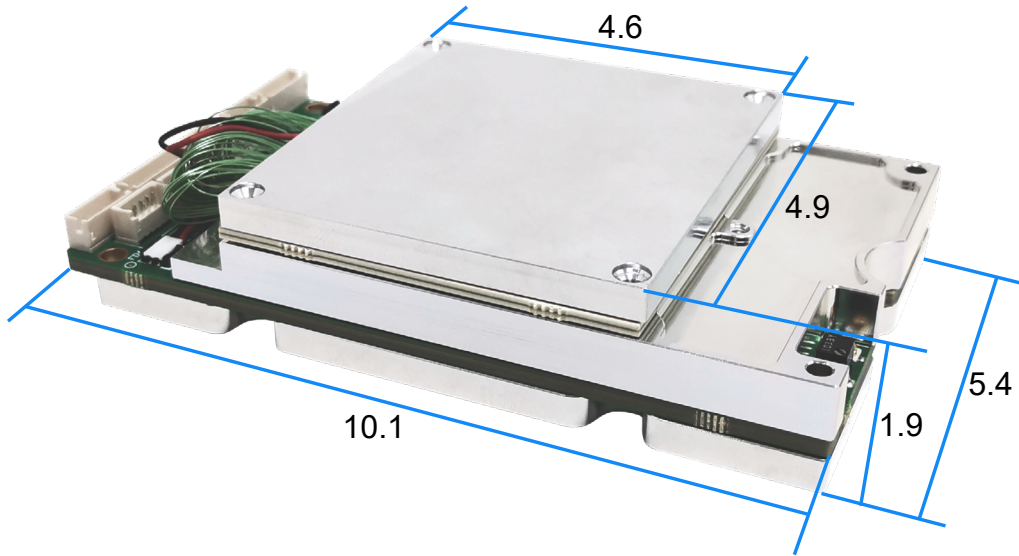

3.6 2Watts×2/4Watts×2 (7Z100)

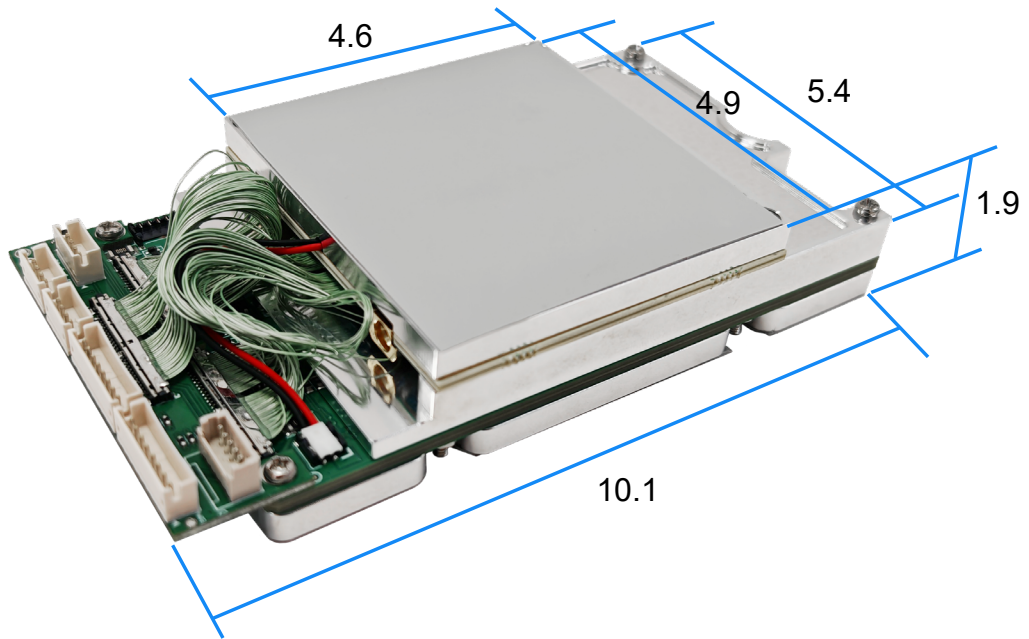

3.7 10Watts×2/20Watts×2

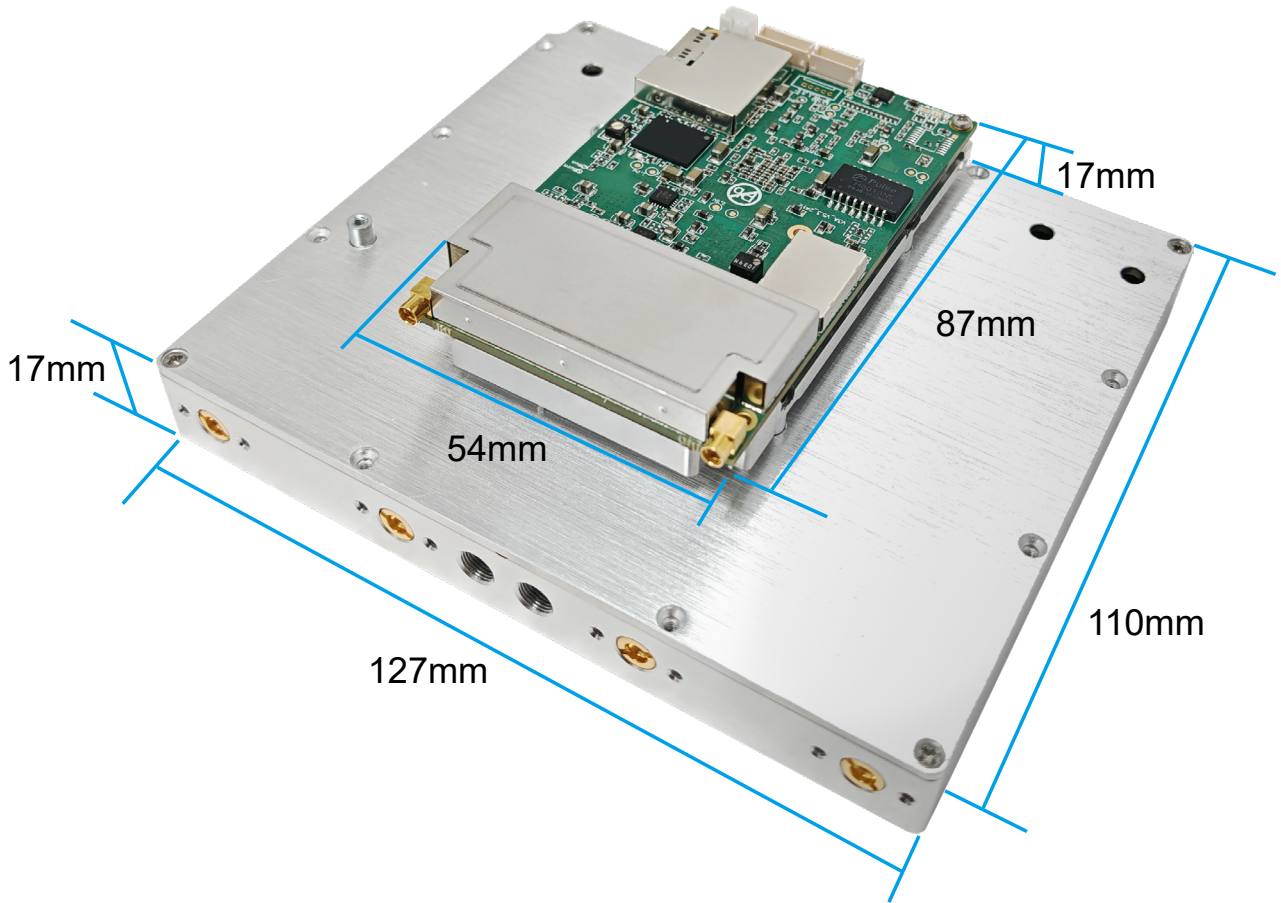

3.8 10Watts×2/20Watts×2

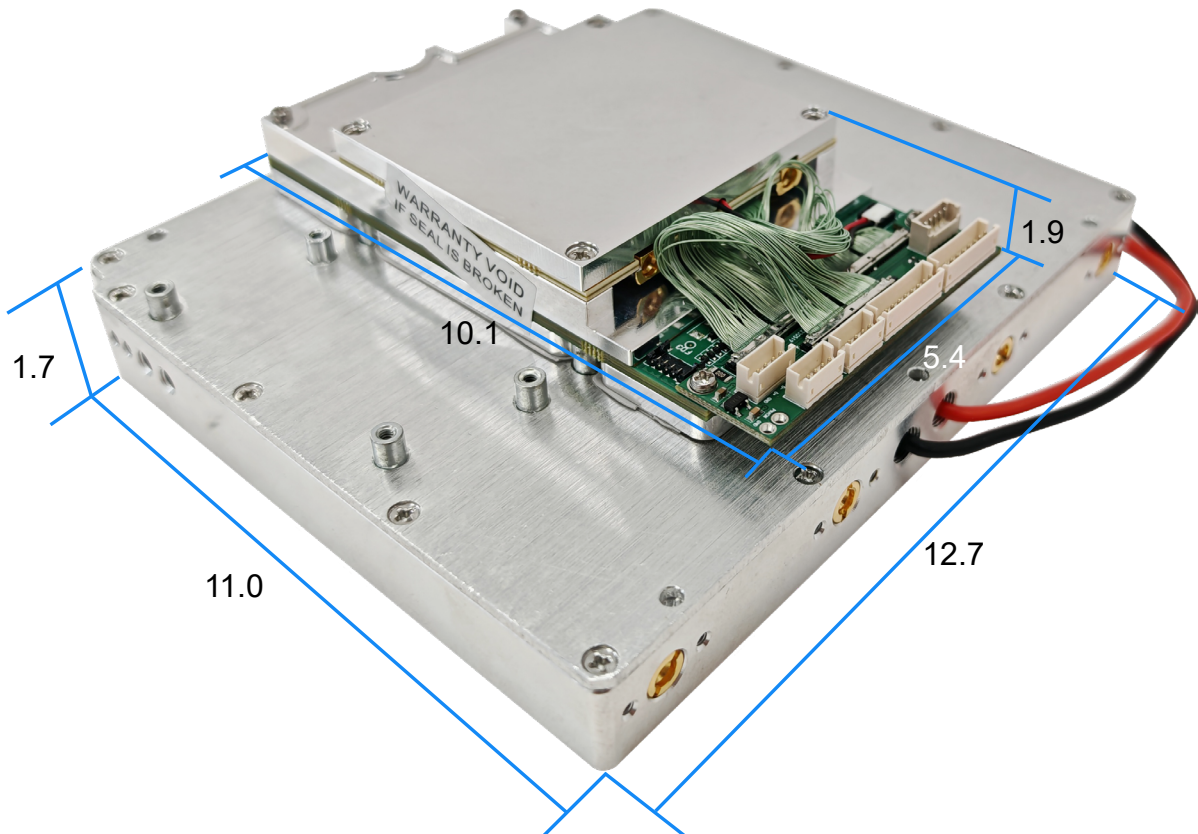

3.9 10Watts×2/20Watts×2

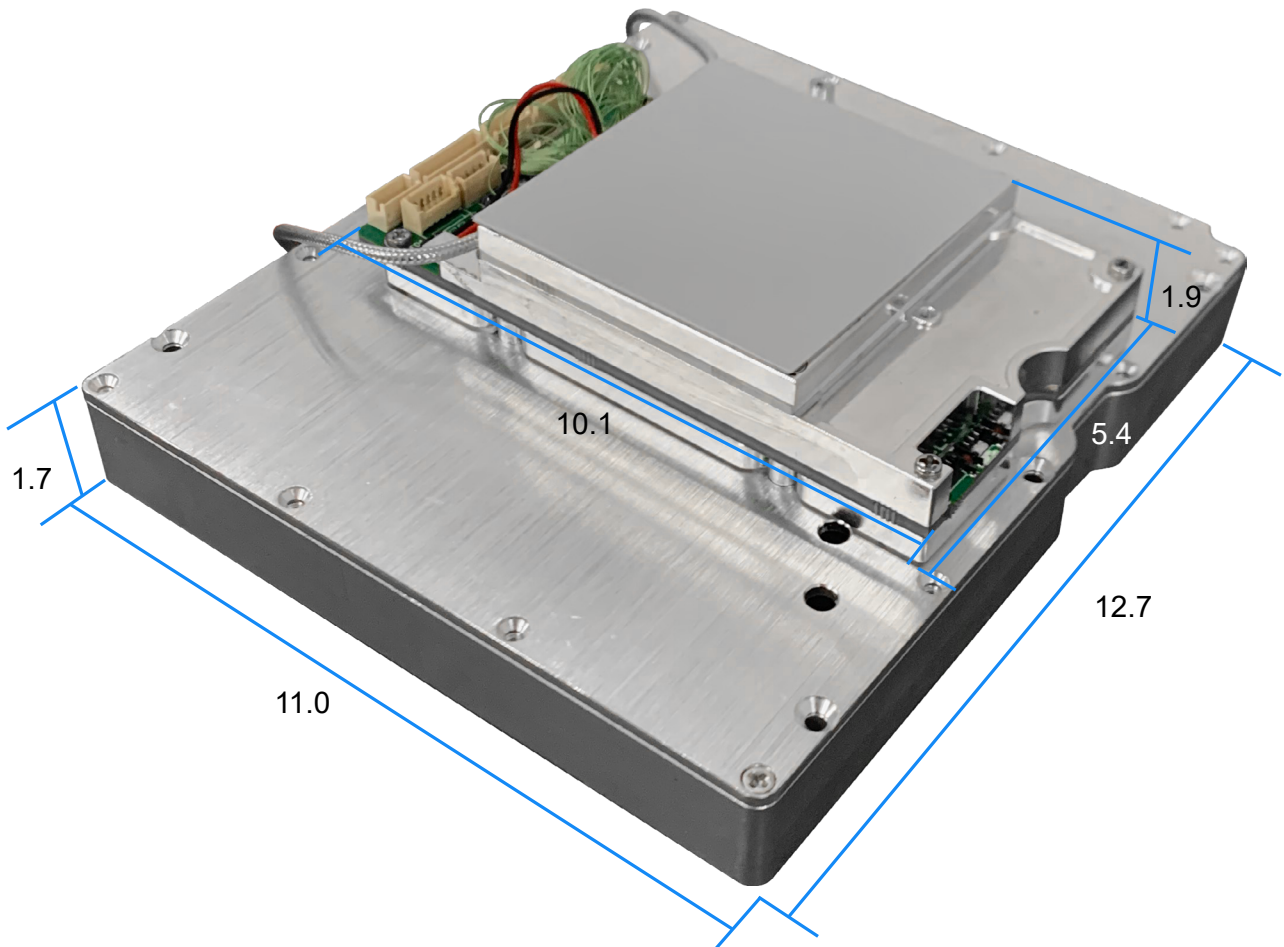

4. Model Name

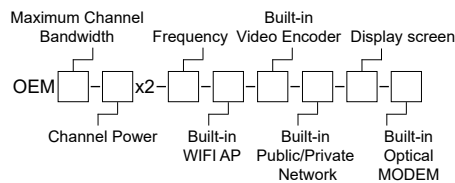

Maximum Channel Bandwidth	Channel Power (W)	Frequency (MHz)	Built-in WIFI AP	Built-in Video Encoder	Built-in Public/Private Network	Display Screen	Built-in Optical MODEM
20	2	600, U	0(N)	0(N)	0(N)	0(N)	0(N)
40	4, 5	1400, L	1(Y)	HDMI	4G/5G	2(2")	1(Y)
80	10	2300, S		SDI/AV	4G LTE CPE	3(3.2")	
	20, 40	4500, C				4(4")	

OEM20-2x2-1400-1-HDMI-4G/5G-0-0 Express: Maximum channel bandwidth 20MHz, 2Watts×2, 1400MHz, With WIFI AP, Built-in HDMI Coding, Built-in 4G/5G Public Network Module, Without display screen and without optical MODEM Module.