

MESH Heterogeneous Internet Gateway Radio

Technical Specification



Handheld

(Mesh+4G/5G Router+Fiber MODEM)



Vehicle

(Mesh+4G/5G Router+Fiber MODEM)



Standard Rack

(Mesh+4G/5G Router+Fiber MODEM)

1. MESH Heterogeneous Internet Gateway Radio Specifications

General			
SDR Platform, Waveform	9361+7Z030/7Z035 or 7Z100, Mobile network MANET+MIMO		
MIMO Technology	Space-time coding, Receive Diversity, TX/RX beamforming, Spatial multiplexing		
Receive Sensitivity	-103dBm@5MHz BW		
Channel Bandwidth	1.25/2.5/5/10/20MHz, 30/40MHz setting; Supports transmission and reception with different channel bandwidths, achieving mixed broadband and narrowband; 80MHz Carrier Aggregation (Dual-antennas with two-frequencies of 40MHz+40MHz for transceiver) optional		
Data Rate	1-130Mbps(20MHz BW)/252Mbps (40MHz BW)/350Mbps(40MHz+40MHz of Carrier Aggregation) Adaptive, QoS		
Modulation Mode	TD-COFDM, BPSK/QPSK/16QAM/64QAM/256QAM/1024QAM Adaptive (Fixed setting optional)		
RF Output Power (Support TPC, transmission power control, 1dBm adjustable)	2Watts*2 10Watts*2		
Single Hop Communication Distance	100-300 KM (LOS), 1-30 KM (urban area)		
Mode	Distributed centerless Point-to-point/Point-to-multipoint/Multipoint-to-multipoint, Layer 2 or 3 of Dynamic routing, Multi-hop relay, Star/Line/Network/Hybrid		
Single Hop Delay	Average 10mS (20MHz BW)		
Encryption	DES, AES128/256, SM4, SNOW3G/ZUC optional, Chip/TF card encryption customized or external encryption machine		
Anti-Jamming Mode	Manual spectrum scanning channel selection/Full band enhanced intelligent frequency selecting(spectrum awareness)/Full band adaptive frequency hopping FHSS/Roaming mode, Multi-level anti-interference		
Local/Remote Management	Operating frequency, channel bandwidth, network ID, transmit power and other parameter settings, spectrum scanning, real-time display and statistical records of network topology, link field strength signal-to-noise ratio, upload and download traffic, node distance, GPS/BD/GLONASS positioning electronic map, temperature/voltage/jamming Monitoring, software upgrade. Remote silence and wake-up optional		
Others	The startup time is less than 28 seconds, and the network access/update/switchover time is less than 1 second There is no limit on the user capacity of a single system (256 nodes or more) and the number of hops in Mesh networks (Data 15+ hops, voice 10+ hops, video 8+ hops). The total bandwidth loss for three hops and above is less than 70%. Automatic carrier tracking, adapted to a Doppler frequency deviation of ± 6 kHz frequency offset, supports mobile communication at speeds above 7200 kilometers per hour (6 Mach, 2000 meters per second)		
Bands(70M-6GHz/Ku-Ka customizable. Same frequency of TDD or different frequency of FDD, of 2T2R at single band or 1T2R at dual-band)			
BAND	Frequency range (MHz)	BAND	Frequency range (GHz)
UHF	430-550/570-700/800-950, 225-400/320-470*	S Band	2.0-2.2/2.2-2.5/2.5-2.7/2.7-2.9/3.4-3.6, 1.6-2.3/1.9-2.7*
L Band	1000-1200/1300-1500/1600-1800/1800-2000, 1200-1700*	C Band	4.4-5.0/5.25-5.85, 4.2-5.2/5.5-6.0*
MIIT	336-344/512-592/566-626/606-678/1420-1520/1430-1444		
Environmental			
Operation Temperature	-40°C ~+80°C		
Protection Level	IP66, IP67/IP68 Customized		
Mechanical		Power	
Size/Weight	20.7x6.9x5.5cm/1.30kg(with 11.1V/7.7Wh battery and WiFi/HDMI/5G Handheld Radio)	Supply Voltage	9-24/12-28VDC (2Watts*2) 18-24/18-36VDC (10Watts*2)
	19.1x18.6x6.3cm/2.16kg (10W*2/20W*2) 48.2x42x8.8cm/5.9kg (19-inch 2U Display Screen Standard Rack Radio)	Power consumption	Operation 1-2A/Standby 0.4-0.6A@12V (2Watts*2) Operation 3-6A/Standby 0.7-0.9A@24V (10Watts*2)
Color	Black, Iron Gray, Army Green Optional	Power Selection	Power Supply by Twist-Lock Battery or Main Cable
Installation	4 Mounting Holes	Batteries	10/6 hours for 114/7.7Wh
Interface			
Basic interface	2xTNC RF, 1-3xRJ45 Ethernet 100/1000BaseT, WiFi AP,GPS/BD,RS232/TTL(UART), Sbus/Bluetooth, 1.2-230.4Kbps, DC Input		
Push to talk/Auxiliary interface	MIC, SP, PTT, GND, RS485/422, USB2.0 OTG		
Network Extension Optional	Public Network Routing/4G LTE, WB-NB integration, Fiber, Satellite		
Video Extension Optional	Low Delay HDMI/SDI/CVBS, 4K/2K/1080P/720P/D1		
Link Status Indicator	Steady red - The network is not connected Blinking red - Starting/not connected to the network Steady green - The network is connected Blinking green - Voice PTT is down		
RSSI Link Indicator	Steady green - The link quality is excellent Steady Blue - The link quality is good Steady yellow - The link quality is medium Steady purple - The link quality is slightly worse Steady red - The link quality is poor or link is down		
Management Interface/ Control Interface	Web-based network management/GUI, API for secondary development interface/SNMP		

2. MESH Heterogeneous Internet Gateway Radio Hardware Interfaces

2.1、Handheld



- 1** HDMI Switch
- 2** RF Channels 1-2 Connectors [TNC Female]
- 3** SIM Card Slot
- 4** Power (EB Version Only, 9-24V), Ethernet, and Serial Port Connector [LF10WBRB-12PD]
- 5** Link Status Indicator
 - Steady red: The network is not connected
 - Blinking red: Starting/not connected to the network
 - Steady green: The network is connected
 - Blinking green: Voice PTT is down

- 6** WiFi Antenna [SMA Female]
- 7** Radio Switch
- 8** 5G Antenna [SMA Female]
- 9** Auxiliary Interface [LF10WBRB-12SD]
- 10** HDMI Port

- RSSI Link Indicator
- Steady green: The link quality is excellent
 - Blue Steady: The link quality is good
 - Steady yellow: The link quality is medium
 - Steady purple: The link quality is slightly worse
 - Steady red: The link quality is poor or link is down
 - Off: The link is interrupted

2.2、Vehicular



- 1** Auxiliary Connection Port [LF10WBRB-12SD]
- 2** WiFi Antenna [SMA Female]
- 3** GPS Antenna [SMA Female]
- 4** Power Switch
- 5** Power supply port (13.8-24V, 13.8/10A)
- 6** Push-to-Talk (PTT) Connector HGG.0B.304
- 7** RS232, Ethernet, and Serial Port Connector [LF10WBRB-12PD]
- 9** RF Channels 1-2 Connectors [TNC Female]

- 8** Link Status Indicator
 - Steady red: The network is not connected
 - Blinking red: Starting/not connected to the network
 - Steady green: The network is connected
 - Blinking green: Voice PTT is down
- RSSI Link Indicator
- Steady green: The link quality is excellent
 - Blue Steady: The link quality is good
 - Steady yellow: The link quality is medium
 - Steady purple: The link quality is slightly worse
 - Steady red: The link quality is poor or link is down
 - Off: The link is interrupted

2.3、Standard Rack

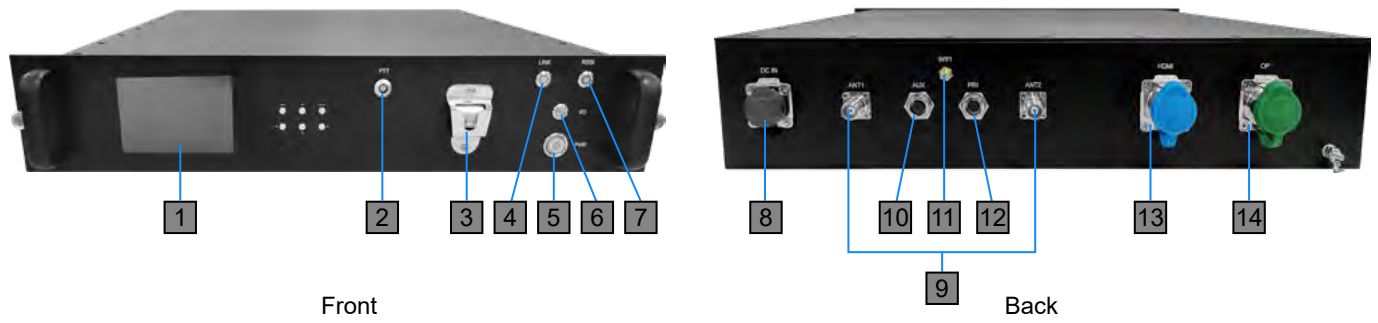

1 Display Screen

2 Push-to-Talk (PTT) Connector HGG.0B.304

3 Voice Hook

4 Link Status Indicator

- Steady red: The network is not connected
- Blinking red: Starting/not connected to the network
- Steady green: The network is connected
- Blinking green: Voice PTT is down

5 Radio switch

6 Power Switch

7 RSSI Link Indicator

- Steady green: The link quality is excellent
- Blue Steady: The link quality is good
- Steady yellow: The link quality is medium
- Steady purple: The link quality is slightly worse
- Steady red: The link quality is poor or link is down
- Off: The link is interrupted

8 Power supply port

9 RF Channels 1-2 Connectors [TNC Female]

10 Auxiliary Connection Port [LF10WBRB-12SD]

11 WIFI Antenna [SMA Female]

12 Serial Port Connector and Ethernet

13 HDMI

14 Optical port [LC interface]

3. MESH Heterogeneous Internet Gateway Radio Connection Port Pin Definition

3.1、Handheld

Power/Ethernet/Serial Connector Pinout	
Enclosure PWR/COMM (LF10WBRB-12PD)	Signal
1	5V OUT (For External GPS Puck)
2	GND IN
3	GND IN
4	VCC IN
5	VCC IN
6	100-Base T ETH0 M2N
7	100-Base T ETH0 M2P
8	100-Base T ETH0 M1P
9	RS232_RXD
10	RS232_TXD
11	RS232_GND
12	100-Base T ETH0 M1N

Table 1 Power/Ethernet/Serial Connector Pinout

RS-232 and PS/2 (GPS) Pinout		
RS-232	DB9 (GPS)	Signal
3	2	TxD
2	3	RxD
NC	NC	NC
NC	9	5V OUT
NC	NC	NC
5	5	Ground

Table 2 Serial and GPS Pinout

USB/GPIO Connector Pinout		
Enclosure USB/GPIO (LF10WBRB-12SD)	Signal	Voice interface definition
1	NA	/
2	NA	/
3	RS458 D-	/
4	USB2_VBUS	AUDIO_GND
5	GPIO1 (PA Enable 3.3V)	/
6	USB2_D+	MIC IN
7	USB2_D-	SPEAKER_OUT
8	RESERVED (Do Not Connect)	PTT
9	GND	/
10	RS458 D+	/
11	NA	/
12	USB2_GND	AUDIO_GND

**Table 3 USB/GPIO Connector Pinout
(USB1 is USB 2.0 OTG, USB2 is USB 2.0 Host Mode Only)**

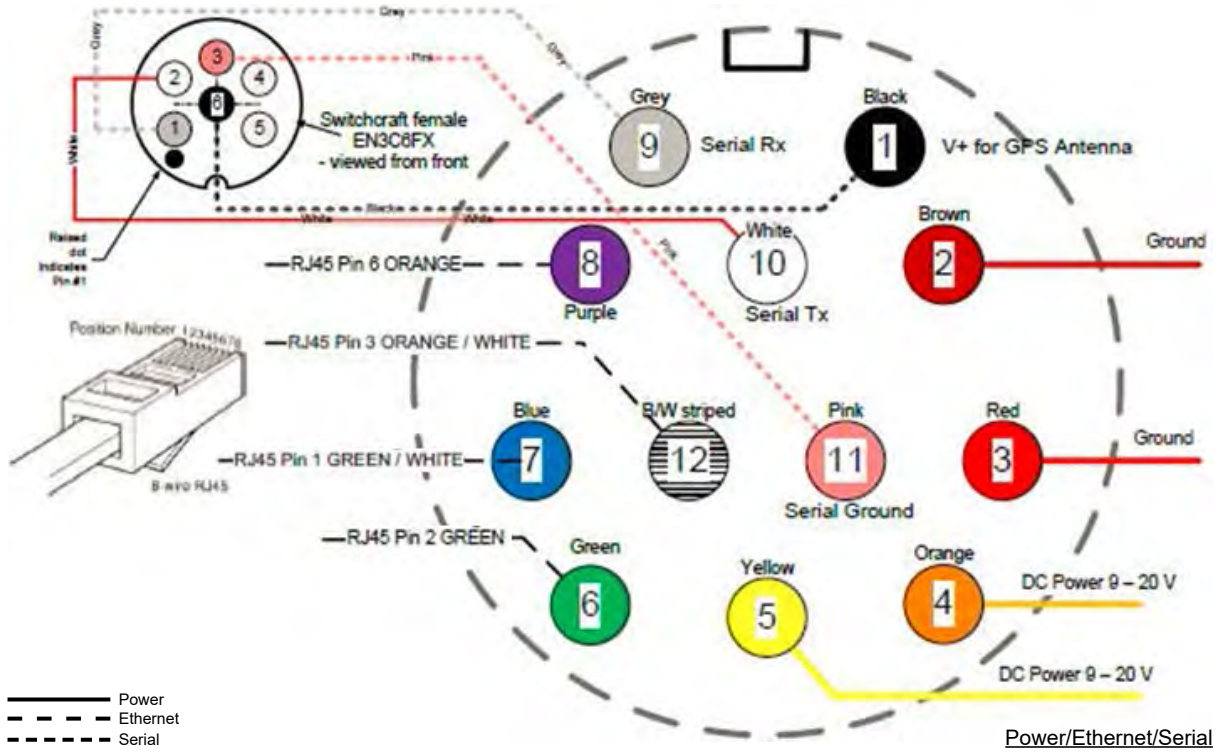

Figure1 Power (Optional)/Serial/Ethernet Pinout Diagram (Cable Side)

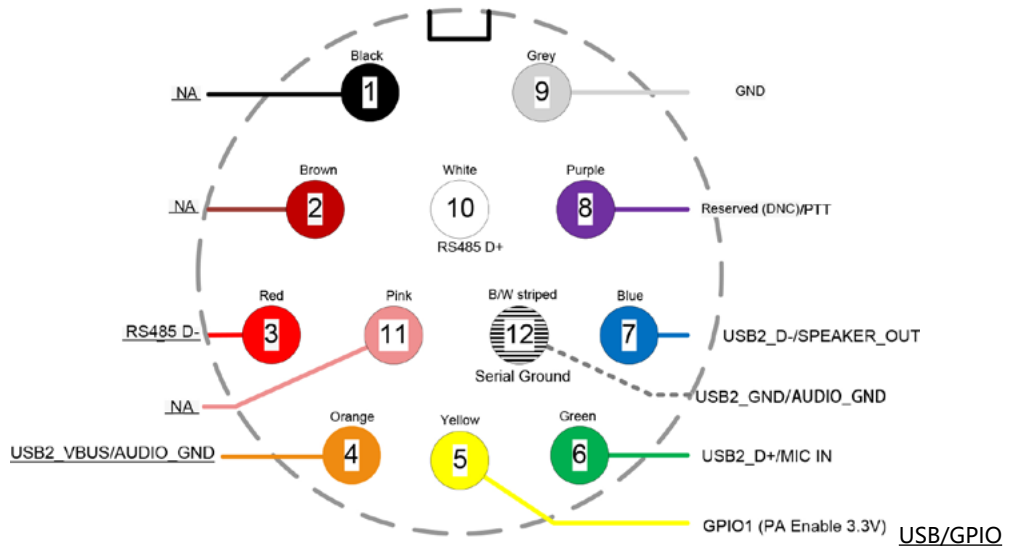

Figure 2 USB/GPIO Pinout Diagram (Cable Side)

3.2、 Vehicular/Standard Rack

Power/Ethernet/Serial Connector Pinout	
Enclosure PWR/COMM (LF10WBRB-12PD)	Signal
1	5V OUT (For External GPS Puck)
2	GND IN
3	GND IN
4	VCC IN
5	VCC IN
6	100-Base T ETH0 M2N
7	100-Base T ETH0 M2P
8	100-Base T ETH0 M1P
9	RS232_RXD
10	RS232_TXD
11	RS232_GND
12	100-Base T ETH0 M1N

Table 1 Power/Ethernet/Serial Connector Pinout

RS-232 and PS/2 (GPS) Pinout		
RS-232	DB9 (GPS)	Signal
3	2	TxD
2	3	RxD
NC	NC	NC
NC	9	5V OUT
NC	NC	NC
5	5	Ground

Table 2 Serial and GPS Pinout

USB/GPIO Connector Pinout		
Enclosure USB/GPIO (LF10WBRB-12SD)	Signal	Voice interface definition
1	NA	/
2	NA	/
3	RS458 D-	/
4	USB2_VBUS	AUDIO_GND
5	GPIO1 (PA Enable 3.3V)	/
6	USB2_D+	MIC IN
7	USB2_D-	SPEAKER_OUT
8	RESERVED (Do Not Connect)	PTT
9	GND	/
10	RS458 D+	/
11	NA	/
12	USB2_GND	AUDIO_GND

**Table 3 USB/GPIO Connector Pinout
(USB1 is USB 2.0 OTG, USB2 is USB 2.0 Host Mode Only)**

PTT Connector(Limited to Backpack Radio)	
Enclosure PTT Connector (ODU GKCWAM-P07UB00-000L)	定义
1	AUDIO_GND
2	PTT
3	SPEAEKR_OUT
4	MIC_IN

Table4 PTT Connector Pinout*(Generally Adopted)

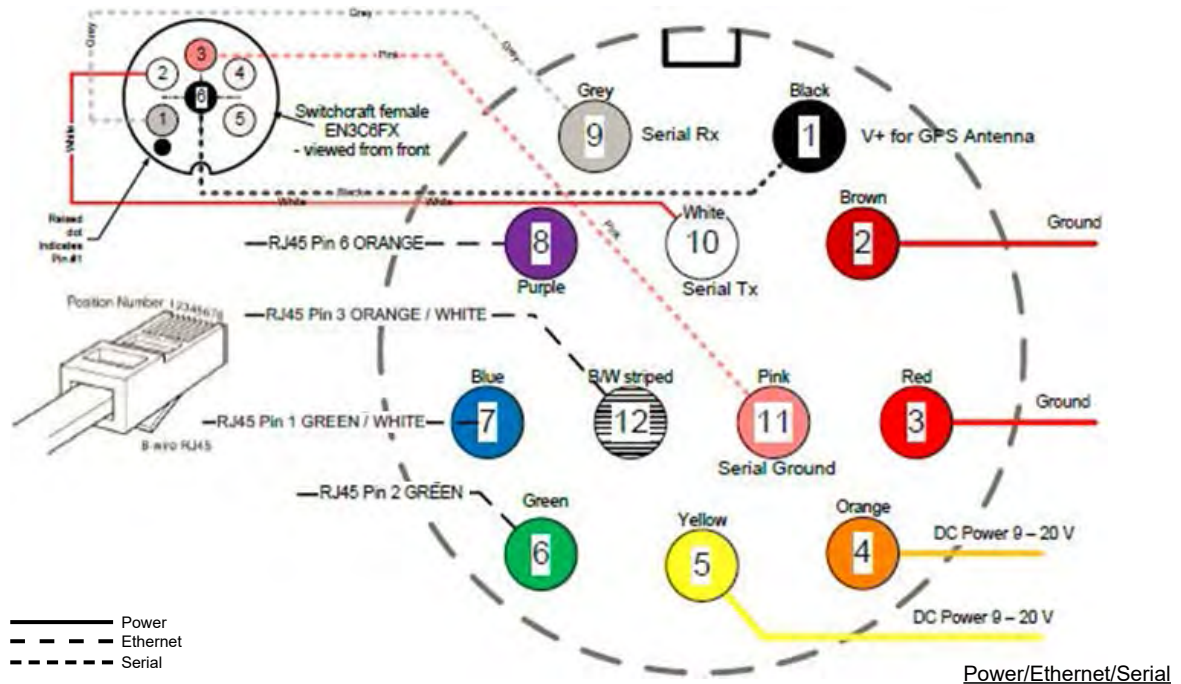

Figure1 Power (Optional)/Serial/Ethernet Pinout Diagram (Cable Side)

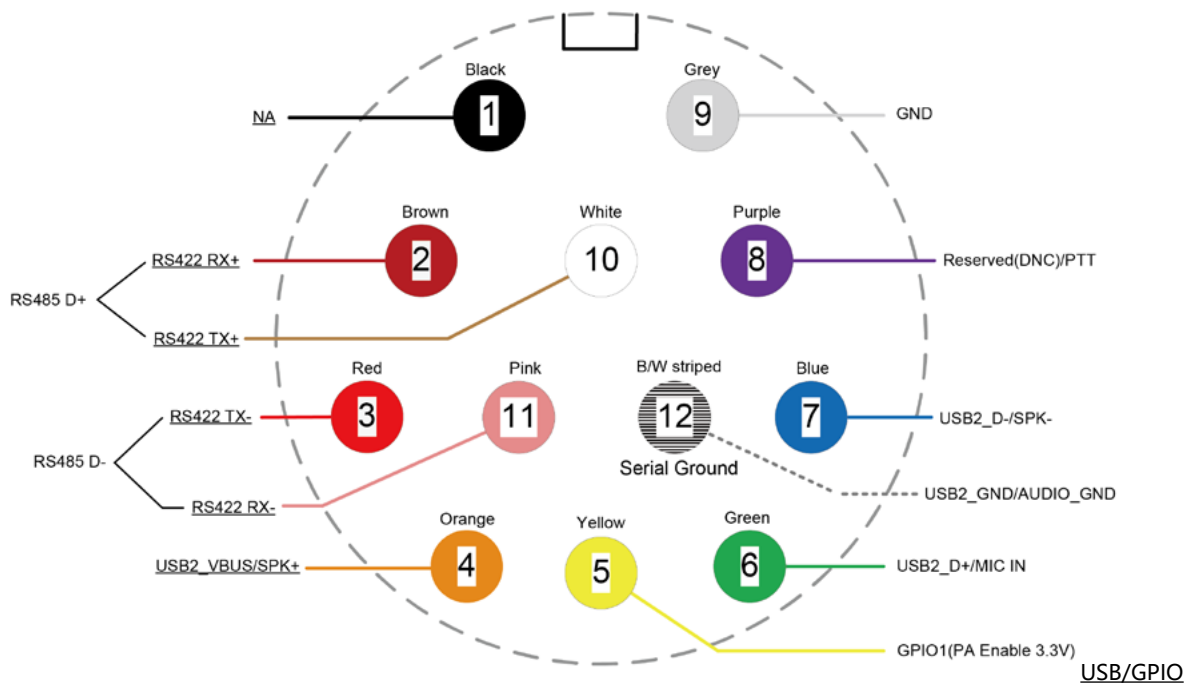

Figure 2 USB/GPIO Pinout Diagram (Cable Side)

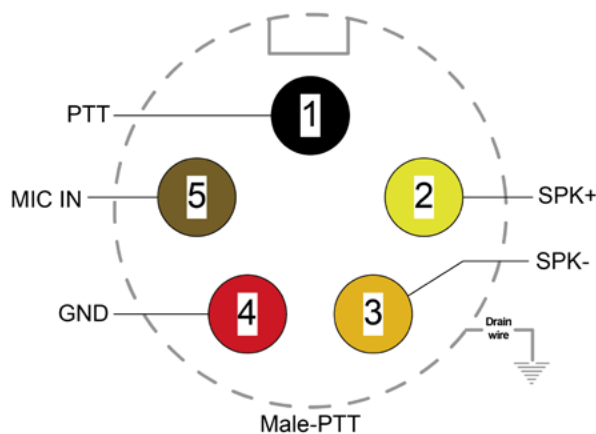
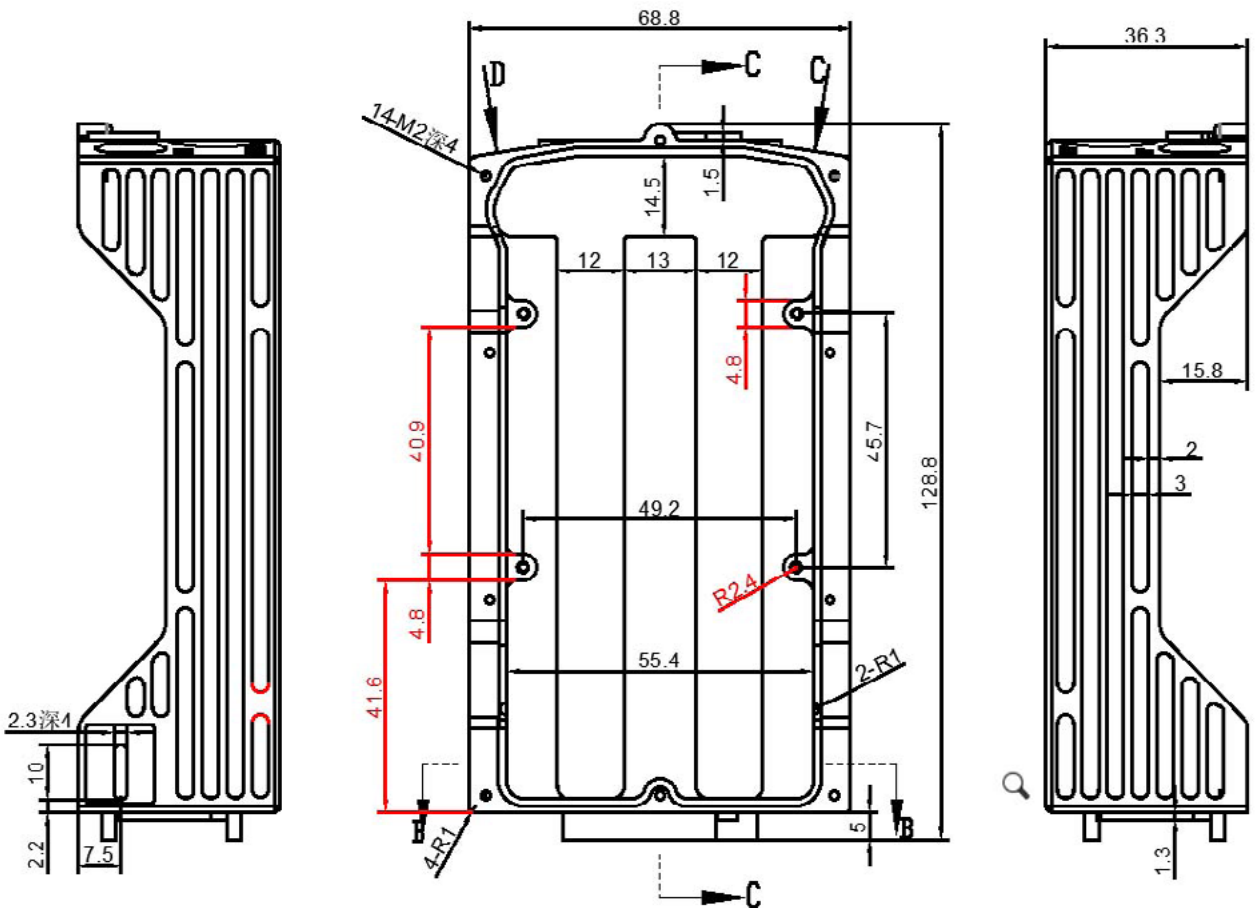
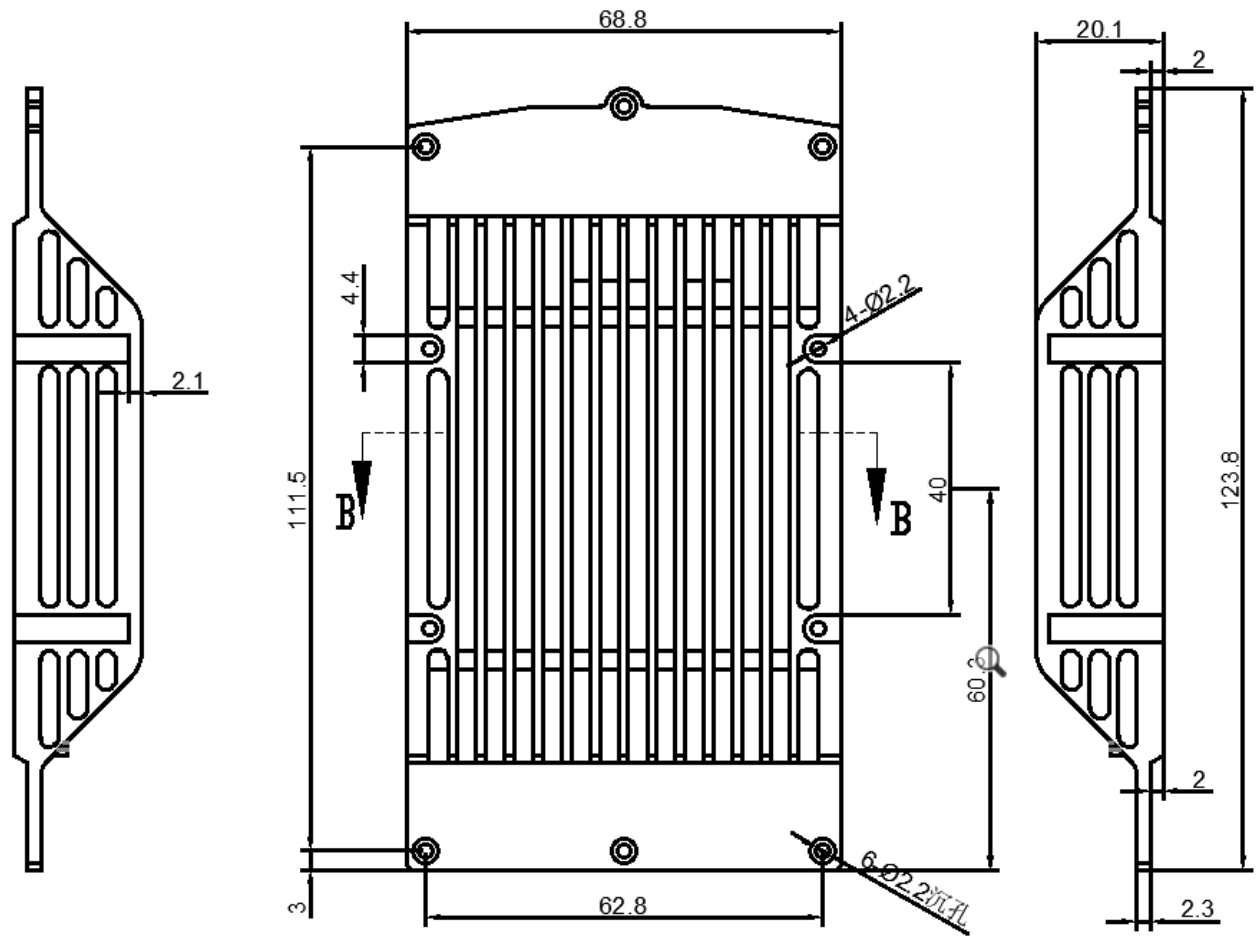

Figure 3 PTT Pinout Diagram (Cable Side)

4. MESH Heterogeneous Internet Gateway Radio Dimension Figure

4.1、Handheld



4.2、 Vehicular

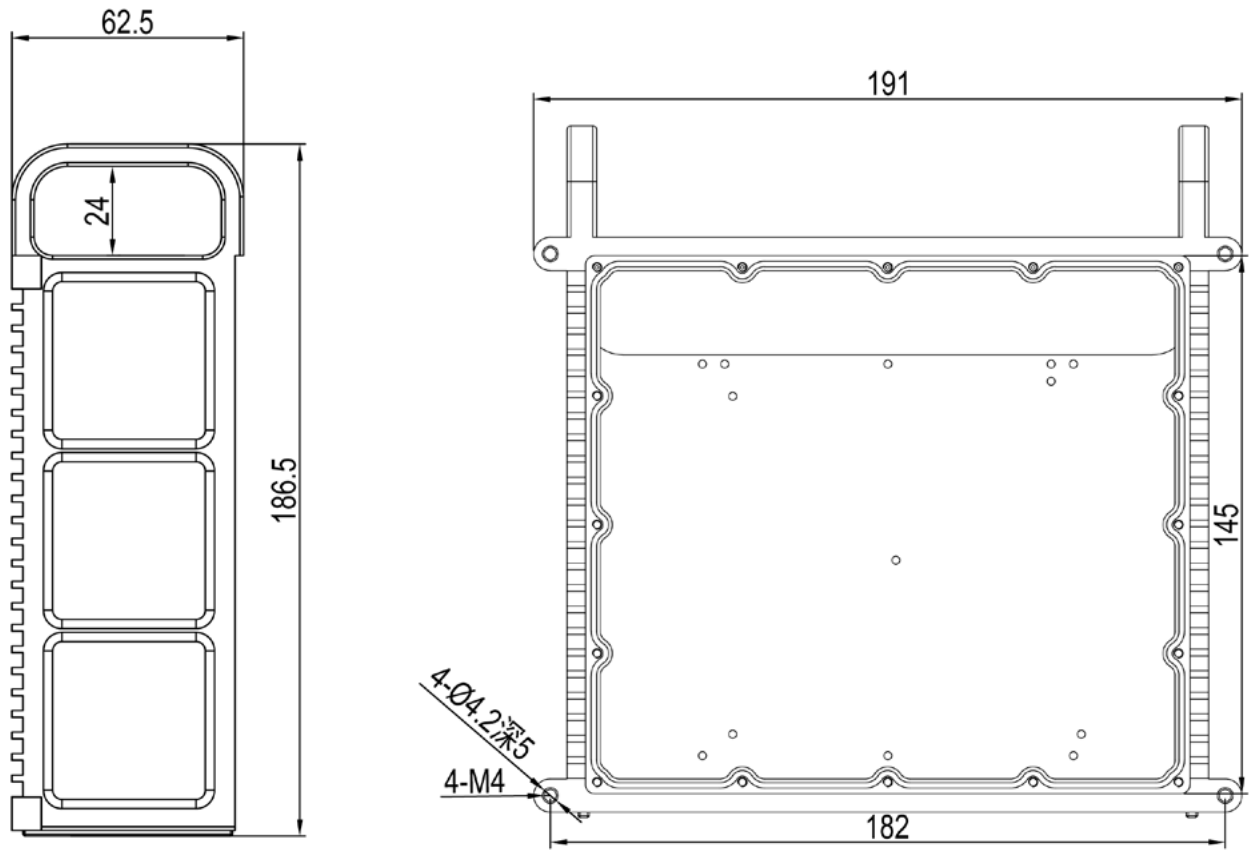

4.3、 Standard Rack

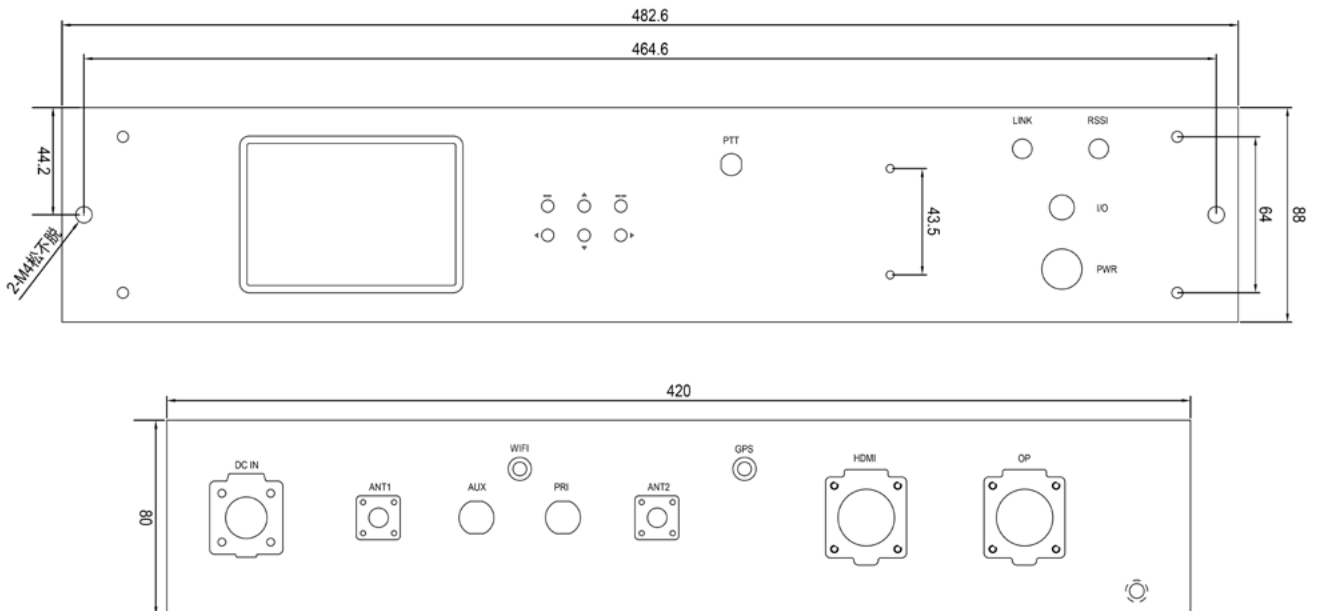

5. Mesh Heterogeneous Internet Gateway 5G Router User Manual

1. Login configuration page

Open IE or other browsers, enter 192.168.2.1 in the address bar, and after the connection is established, log in as the system administrator (admin) on the pop-up login interface, that is, enter the password on the login interface (the factory default password is admin).



2. SIM card 3/4/5G mode to access the Internet

The router uses SIM card 3/4/5G to access the Internet by default. You can see the SIM card information in the navigation bar "Route Status" - "Status". In the upper right corner, you can check whether the network is 3/4/5G and the mobile phone card signal.

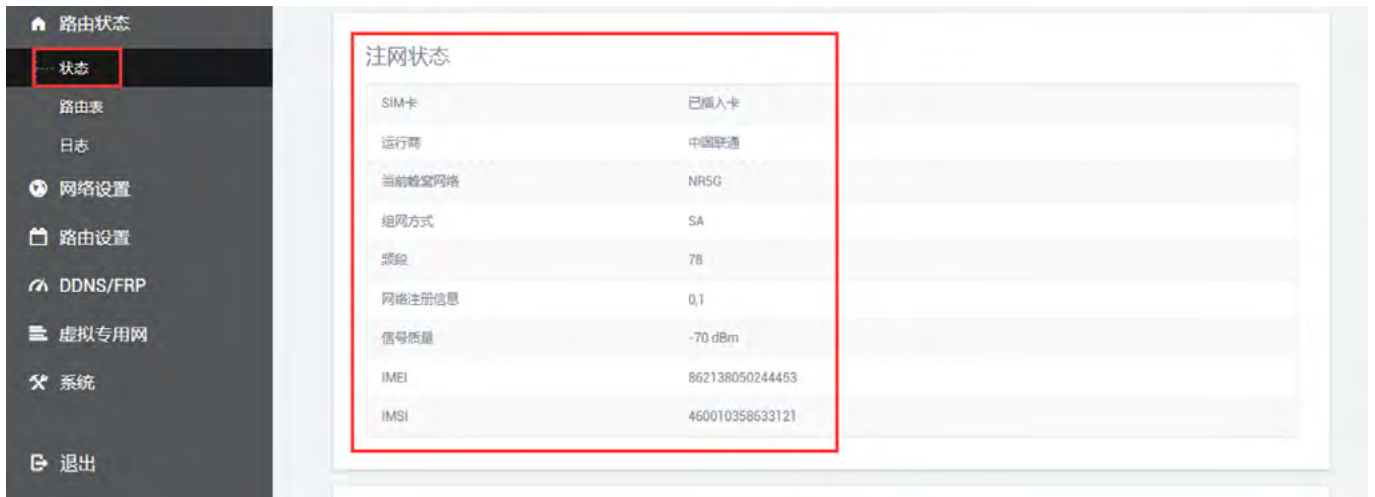

3. Network Settings

"Network Settings" - "5G Network" - "Advanced Settings" can bind 3/4/5G. If the service type is NR5G Only, it means that only 5G network is used. If it is not 5G, there will be no network automatically. The default is 3/4/5G. The one with stronger network signal will be used first, and 5G is used first. The frequency band is locked automatically, and the frequency band with good signal is selected first. You can also lock the frequency band according to your needs. If the locked frequency band is unsuccessful, it means that the module does not support this frequency band temporarily. After the settings are completed, click "Save and Apply".



4. Network Diagnostics

It is to deal with network anomalies. It will ping the set IP address every 5 seconds. If it still cannot ping after the abnormal number of pings, it will re-register the network. You can set network diagnosis in "Basic Settings" and "Advanced Settings". If you need to use the network, just check Enable.

