

# FGR2/MM2

## FHSS Wireless Data Transceivers

### User Manual and Reference Guide



MM2 (5.1x3.6x0.96cm)  
(153.6k/1.2Mbps, TTL, 5.0V, 1-2W, MMCX)



EL805 (9.1x12.9x2.3cm)  
(115.2kbps, 232/485/422, 7-30V, TNC)



FGR2-CE(N920)  
(5.7x9.8x4.3/11x5.8x2.3cm, 228/136g)  
(153.6k/1.2Mbps, 232/485/422, 7-30V, TNC)



FGR2-多串口  
(11.4x9.8x4.3/8.7x5.4x2.2cm, 300/135g)  
(153.6k/1.2Mbps, 多串口, 232/485/422, 7-30V, TNC)



FGR2-15瓦  
(15.1x11.5x6.2/17.1x11.2x3.2cm, 900/680g)  
(153.6k/1.2Mbps, 15瓦, 232/485/422, 10.5-16V/4A, TNC)



# MM2(FGR2)/NANO Series of FHSS



**MM2-T**  
902-928MHz



**F50EX008**  
225-400MHz



**Q508X600**  
228-235MHz



**N920/N320/N425/N1350**  
902-928M/310-390M/410-480M/1.35-1.39GHz

## Overview:

MM2 radio has been designed to provide the performance, reliability, and quality that our customers have come to know and expect in our products in our products in a MM2 "Mega-Mini" form factor for applications where space is at a premium. The MM2 has all of the functionality of the larger footprint FGR Series of radios.

## Features:

- Improved Low Signal Performance: RISC - based signal demodulation with matched filter.
- Versatility: A single radio can operate as a master, slave, repeater, or slave/repeater.
- Unparalleled Signal Performance: GaAs FEI RF front end with multistage SAW filtering has unmatched combination of overload immunity and sensitivity.
- High Noise Immunity: Superior performance in noise congested environments.
- TDMA: Time Divisible Multiple Access available.
- 115.2 - 153.6kbps
- Secure: Proprietary spread spectrum technology prevents detection and unauthorized access; 128 bit AES encryption available\*.
- Reliability: Every radio 100% tested for RF performance from -40°C to +85°C .
- Size & Performance: Smallest data radio with the highest performance available.
- Low power consumption.
- UL Approved\*\*



**MM2-T**  
(5.1 × 3.6 × 1.0cm, 14g)  
(TTL, 3.5/5.0V, MMCX)



**FGR2 (N920/N320/N425)**  
(5.7x9.8x4.3/11.0x5.8x2.3cm, 228/136g)  
(153.6k/1.2Mbps, 232/485/422, 7-30V)



**MDS EL805 compatible Digi 9XTend compatible**  
(115.2kbps, 232/485/422, 7-30V)



**FGR2-Multi-port**  
(11.4x9.8x4.3/8.7x5.4x2.2cm, 300/135g)  
(153.6k/1.2Mbps, Multi-port, 232/485/422, 7-30V)



**FGR2-15Watts**  
(15x12x6/11x8x4cm, 900/300g)  
(19.2-345kbps, 232/485/422, 10.5-16V/4A)

# MM2(FGR2)/NANO Series of FHSS

## MM2-TTL 900MHz Series Technical Specifications

Transmitter				
Frequency Range	902-928M/225-400(228-235)M/310-390M/410-480M/1.35-1.39GHz(FHSS)(DTS)			
Output Power	10 mW to 1 W, 1 to 2W (Military & rxport versions only)			
Range - Line of Sight	60miles			
Modulation	2 level GFSK			
RF Data Rate	Selectable speeds 115.2 to 153.6kbps(MM2), 115.2k to 1.2Mbps(N920/N320/N425/N1350)			
Occupied Bandwidth	230kHz/611.2kHz			
Hopping Patterns	15 per Band, 105 total, user selectable			
Hopping Channels	50 to 112, user selectable			
Hopping Bands	7, user selectable			
Frequency Zones	16 Zones			
RF Connector	MMCX(Straight)			
Receiver				
Sensitivity	-108(MM2)/-107(N1350)/-106(N920/N320/N425)dBm @ 115.2 kbps for BER10 <sup>-4</sup> -103dBm @ 153.6 kbps for BER10 <sup>-4</sup> -100dBm @ 1.2 Mbps for BER10 <sup>-4</sup>			
IF Selectivity	40 dB at fc +/-230 kHz			
RF Selectivity	50 dB at 896 MHz, 935MHz			
Dynamic Range	+10 dBm 3rd Order Intercept Point at Input Connector			
DATA Transmission				
Error Detection	32 bit CRC, Retransmit on error			
Data Encryption	Proprietary Spread Spectrum Technology			
Data Interface	1200bps - 230.4kbps			
Data Connector	Straight 14-pin dual row header 2.0mm spacing			
Data Throughput	115.2-153.6kbps(MM2), 115.2k-1.2Mbps(N920/N320/N425/N1350)			
Power Requirements				
Operating Voltage	MM2:+5 VDC(+/-5%), N920/N320/N425/N1350: 3.3 VDC(+/-3%)			
Current(mA)	Mode	+5VDC(MM2)	+3.3VDC(N920/N320/N425)	+3.3VDC(N1350)
	Transmit	635mA	1.3A	100mA
	Receive	135mA	160mA	120mA
	Idle	19mA	20mA	20mA
	Sleep	6mA	1mA	1mA
General Information				
Operating Temperature Range	-40°C to +80°C (-40 °F to +185 °F )			
Dimensions	50.8 L x 36 W x 9.6 H(mm)(MM2), 32 L x 51 W x 6.35 H(mm)(N920/N320/N425/N1350)			
Weight	14g(MM2), 18g(N920/N320/N425/N1350)			
Humidity	0 to 95% non-condensing			



## Shenzhen Sinosun Technology Co.,Ltd.

Address: Room 3A17, South Cangsong Building, Tairan Science Park, Futian District, Shenzhen City, Guangdong Province, P. R. China.  
 Postcode: 518040 Phone: +86 755 83849417 83435240 Fax: +86 755 83849434 E-mail: 13823678436@139.com WWW.SINOSUN.CN  
 Johnson: +86 13902912908(Mobile&WeChat) +852 44017395(Mobile&WhatsApp) Tony: +86 13823678436(Mobile&WeChat)  
 Beijing: +86 13811936491 Shanghai: +86 13564038257 Chengdu: +86 13540153264 Xi'an: +86 13991217256

---

# Table Of Contents

<b>Preface</b> .....	<b>x</b>
<b>Chapter 1: Introduction</b> .....	<b>1</b>
Choosing a Location for the Transceivers .....	2
Choosing Point-to-Point or Point-to-MultiPoint Operation .....	2
Data Communication Link Examples .....	3
Finding the Product Serial Number .....	5
<b>Identifying Your Transceiver Model</b> .....	6
Powering the Transceiver .....	7
Configuration Tool Options .....	7
Tool Suite and Terminal Emulators .....	8
Transceiver Setup Mode .....	9
Using Tool Suite to Connect to and Program Transceivers .....	9
Accessing the Setup Menu Using a Terminal Emulator .....	11
Connecting and Disconnecting from HyperTerminal .....	15
Troubleshooting HyperTerminal .....	15
Upgrading Transceivers to the Latest Firmware .....	17
<b>Chapter 2: Basic Transceiver Programming and Setup</b> .....	<b>18</b>
Setting the Transceiver's Role in the Network and the Network Type .....	18
Establishing Communication with Instrumentation and Computers .....	20
Baud Rate .....	21
Data Parity .....	21
Flow Control .....	21
Modbus RTU .....	22
Serial Interface .....	22
Setup Port .....	23
Turn Off Delay .....	24
Turn On Delay .....	24
Use Break to Access Setup .....	24
Establishing Communication with Other Transceivers in the Network .....	25
"Golden Settings" .....	25
Setting RF Transmission Characteristics .....	26
Frequency Key (Golden Setting) .....	26
Frequency Zones .....	27
High Noise .....	29
Hop Table Size .....	30

---

Hop Table Version .....	30
Max Packet Size and Min Packet Size (Golden Setting) .....	31
MCU Speed .....	33
Remote LED .....	33
Retry Time Out .....	34
RF Data Rate (Golden Setting) .....	34
RTS to CTS .....	35
Slave Security .....	36
Transmit Power .....	36
Transmit Rate .....	37
<b>Chapter 3: Configuring Point-to-MultiPoint Networks .....</b>	<b>38</b>
Point-to-MultiPoint Network Characteristics .....	39
Golden Settings .....	39
Master-to-Slave Communication .....	39
Slave-to-Master Communication .....	39
Point-to-MultiPoint Network Quick Start .....	39
Point-to-MultiPoint Operation LEDs .....	42
Overlapping MultiPoint Networks .....	42
Establishing Communication with Other Transceivers in a MultiPoint Network .....	42
Using the Network ID in MultiPoint Networks .....	43
Using the Call Book in MultiPoint Networks .....	43
Programming Point-to-MultiPoint Extended Call Book .....	44
Routing Communication Through the Network .....	44
Assigning Subnet ID Values .....	45
Setting Other MultiPoint Parameters .....	47
1 PPS Enable Delay .....	47
Diagnostics .....	48
DTR Connect .....	49
Local Mode .....	49
Master Packet Repeat .....	49
Master Packet Repeat in MultiPoint Networks with Repeaters .....	50
Max Slave Retry .....	50
Radio ID .....	51
Radio Name .....	51
Repeater Frequency .....	51
Repeaters .....	51

Retry Odds.....	52
Slave/Repeater.....	52
Conserving Power.....	53
Low Power Mode.....	53
Reading Diagnostics in Tool Suite.....	55
<b>Chapter 4: Configuring Point-to-Point Networks.....</b>	<b>56</b>
Point-to-Point Network Quick Start.....	56
Point-to-Point Operation LEDs.....	59
Using the Call Book in Point-to-Point Networks.....	59
Programming Point-To-Point Extended Call Book to Use Three or Four Repeaters.....	61
<b>Chapter 5: Advanced Programming.....</b>	<b>62</b>
Working with Parallel Repeaters.....	62
Setting Transceiver Passwords.....	64
About AES Encryption.....	65
Encryption.....	65
Encryption Key.....	66
Low Baud Rates.....	67
Multi-Master Synch.....	67
Time Divisible Multiple Access (TDMA).....	67
<b>Chapter 6: Viewing Radio Statistics.....</b>	<b>69</b>
Antenna Reflected Power.....	69
Master-Slave Distance.....	70
Noise Level.....	70
Number of Disconnects.....	70
Radio Temperature.....	70
Rate %.....	70
Signal Level.....	71
Transmit Current.....	71
<b>Chapter 7: Troubleshooting.....</b>	<b>72</b>
Troubleshooting Flowchart.....	73
Troubleshooting.....	74
<b>Chapter 8: Additional Transceiver Information.....</b>	<b>77</b>
<b>MM2-T/MM2-LV-T Board-Level Pinout.....</b>	<b>77</b>
<b>MM2-MR-R/MM2-MR-T Board-Level Pinout.....</b>	<b>78</b>
MM2-T Model Specifications.....	79
Operational RS422 and RS485 Information.....	80
RS422 Full Duplex Pin-Outs.....	81
RS485 Half Duplex Pin-Outs.....	81

---

RS232 Pin Assignments (DB-9).....	81
900 MHz Transceiver Specifications.....	83
<b>MM2-LV-T Model Specifications</b> .....	<b>85</b>
<b>MM2-R Model Specifications</b> .....	<b>87</b>
<b>MM2-T/MM2-LV-T Mechanical Drawing</b> .....	<b>89</b>
<b>MM2-MR Mechanical Drawing</b> .....	<b>90</b>
Factory Default Settings.....	91
<b>Appendix A: Firmware Updates</b> .....	<b>92</b>
FGR2 ( MM2 ) 快速设置步骤.....	<b>94</b>
FGR2-CE多串口电台使用说明.....	<b>98</b>

---

# Preface

---

This document applies to the following models in the MM2 MM2 family:

- MM2-T
- MM2-LV-T
- MM2-MR-R
- MM2-MR-T
- MM2-T-U
- MM2-LV-T-U
- MM2-MR-R-U
- MM2-MR-T-U
- MM2-T-A1
- MM2-LV-T-A1
- MM2-MR-R-A1
- MM2-T-A2
- MM2-LV-T-A2
- MM2-MR-R-A2

This document includes the following regarding the FreeWave FGR2 transceivers:



- A basic introduction to the transceiver and how to determine the mode you want to run it in.
- Examples of how FreeWave transceivers can exist in a network with other transceivers.
- How to access the setup parameters available on the transceiver.
- Basic transceiver programming and setup information that applies to all network types.
- Considerations and quick starts for your network design, including charts of LED displays.
- Details about defining a MultiPoint network including the use of subnet IDs to route information through the network.
- Steps to view statistics about a transceiver's performance.
- Pin out and mechanical drawings.

For information about the firmware releases that apply to the transceiver, see Appendix A.

The contents of this document assumes that you have a basic understanding of Tool Suite and its components. For more information about using Tool Suite, see the *Tool Suite User Manual* available on the *User Manual and System Tools* CD or by selecting **File > Help** in the Tool Suite software.

## Notational Conventions

This guide uses the following notational conventions:

- **Bold** - Indicates items that you select, parameter settings, and parameter names.
-  **Warning!** - Indicates a situation that might cause damage to your radio, data, or network.
-  - Provides time saving or informative suggestions about using the product.

The term "radio" and "transceiver" are used throughout this manual to refer to the FGR2 radios.

## Contacting FreeWave Technical Support

For up-to-date troubleshooting information, check the Support page at [www.freewave.com](http://www.freewave.com).

FreeWave provides technical support Monday through Friday, 7:30 AM to 5:30 PM Mountain Time (GMT -7). Call toll-free at 1.866.923.6168, within Colorado call 303.381.9200, or contact us through email at [moreinfo@freewave.com](mailto:moreinfo@freewave.com).

## Documentation Feedback

Your feedback is important to us! FreeWave Technologies, Inc. is committed to continually improving the quality of our documentation. If you have any comments or suggestions about this document, send them to us at [techpubs@freewave.com](mailto:techpubs@freewave.com). Please include the title of the document or the document's part number in your email.

## Additional Information

This guide covers settings and configurations that apply to FreeWave spread spectrum transceivers. Some transceiver models have specific settings and configurations that apply to only that model. For information about a specific model or additional information about using the radios in your network, see the addendums and application notes listed below.

- *Cathodic Protection User Manual Addendum*
- *FGR Radio Modem in Mirrored Bit Mode User Manual Addendum*
- *Application note #5412: Synchronizing Collocated Masters (Multi-Master Sync Mode)*
- *Application note #5476: Mode 6*
- *Application note #5424: Using the FGR-115MB Radio with Schweitzer Engineering Labs Mirrored Bits Communications*
- *Application note: #5437: DTR to CTS Line Alarm Feature*
- *Application note #5457: Local Mode*

For information about installing your transceivers, see the *900 MHz Wireless Transceiver Installation Guide*.

All FreeWave documentation is available on the *User Manual and System Tools CD* and at [www.freewave.com](http://www.freewave.com).

---

# Chapter 1: Introduction

---

FreeWave transceivers operate in virtually any environment where serial data communications occur. A pair of transceivers functions as a 9-pin null modem cable. If the FreeWave transceivers are to be used in an application where a null modem cable is used, such as communication between two computers, then the FreeWave transceivers can be connected directly. If FreeWave transceivers are to be used to replace a straight-through RS232 cable, then a null modem cable must be placed between the transceiver and the Data Communication Equipment (DCE) instrument to which it is connected.

FreeWave transceivers operate in virtually any environment where data communications occur. The radios act as data transmission devices, duplicating data in either Point-to-Point or Point-To-MultiPoint mode.

The FGR2 consists of an MM2-T (the top board) and a power amplifier (bottom board).





**Warning!** Do not connect the MM2-9X5W transceiver to DC power without terminating the antenna port to a suitable load, such as a 50 ohm antenna, or an attenuator with a power rating greater than or equal to 5 W. Powering up without a load attached will damage the transceiver and void the warranty.

---

## Choosing a Location for the Transceivers

Placement of the FreeWave transceiver is likely to have a significant impact on its performance. The key to the overall robustness of the radio link is the height of the antenna. In general, FreeWave units with a higher antenna placement will have a better communication link. In practice, the transceiver should be placed away from computers, telephones, answering machines, and other similar equipment. The RS232 cable included with the transceiver usually provides ample distance for placement away from other equipment. FreeWave Technologies, Inc. offers directional and Omni directional antennas with cable lengths ranging from 3 to 200 feet. When using an external antenna, placement of that antenna is critical to a solid data link. Other antennas in close proximity are a potential source of interference; use the Radio Statistics to help identify potential problems.

The Show Radio Statistics page is found in option 4 in the main terminal menu or in the Diagnostic information in Tool Suite. An adjustment as little as 2 feet in antenna placement can resolve some noise problems. In extreme cases, such as when interference is due to a Pager or Cellular Telephone tower, the band pass filters that FreeWave offers, may reduce this out-of-band noise.

## Choosing Point-to-Point or Point-to-MultiPoint Operation

A Point-to-Point network is best suited when your network consists of one Master and one Slave transceiver. You can add up to four Repeaters to extend the reach of the network.

---

**Important:** Adding a Repeater to a network cuts the network throughput by 50%.

---

In a Point-to-MultiPoint network (also referred to as MultiPoint network) the Master transceiver is able to simultaneously communicate with numerous Slaves. In its simplest form, a MultiPoint network functions with the Master broadcasting its messages to all Slaves. If requested by the Master, the Slaves respond to the Master when given data by the device connected to the data port. This response depends on your setup. You can extend the reach of the network with as many Repeaters as is required. As with Repeaters in a Point-to-Point network, adding Repeaters to a network cuts the throughput by half.

It is important to note the differences between Point-to-Point and MultiPoint networks. In a Point-to-Point network all packets are acknowledged, whether sent from the Master to the Slave or from the Slave to the Master. In a MultiPoint network, you determine the number of times outbound packets from the Master or Repeater to Slaves or other Repeaters are sent. The receiving transceiver, Slave or Repeater, accepts the first packet received that passes the 32 bit CRC. However, the packet is not acknowledged. On the return trip to the Master, all packets sent are acknowledged or retransmitted until they are acknowledged. Therefore, the return link in a MultiPoint network is generally very robust.

Traditionally, a MultiPoint network is used in applications where data is collected from many instruments and reported back to one central site. The architecture of such a network is different from Point-to-Point applications. The following parameters influence the number of transceivers that can exist in a MultiPoint network:

1. Data block size. The longer the data blocks, the fewer number of deployed Slaves can exist in the network.
2. Baud rate. The data rate between the transceiver and the device to which it is connected could limit the amount of data and the number of transceivers that can exist in a network
3. The amount of contention between Slaves. Polled Slaves vs. timed Slaves.
4. Repeater Use. Using the **Repeater** setting in a Point-to-Point or MultiPoint network decreases overall network capacity by 50%.

For example, if the network polls Slaves once a day to retrieve sparse data, several hundred Slaves could be configured to a single Master. However, if each Slave transmits larger amounts of data or data more frequently, fewer Slaves can link to the Master while receiving the same network performance. When larger amounts of data are sent more frequently, the overall network bandwidth is closer to capacity with fewer Slaves.

## Data Communication Link Examples

FreeWave transceivers' versatility allows data communication links to be established using a variety of different configurations.

The example below shows the most common and straight forward link; a communicating to a Slave in a Point-to-Point link.

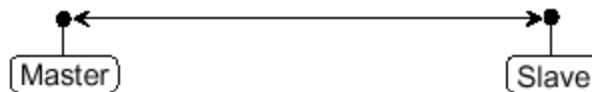

The example below shows how a link might be set up using a Repeater. The Repeater may be located on a hilltop or other elevated structure enhancing the link from the Master to the Slave. In this configuration, it may be desirable to use an external Omni directional antenna at the Repeater. Yagi antennas may be used at both the Master and Slave transceivers.

When a Repeater is used, the RF throughput is cut in half.

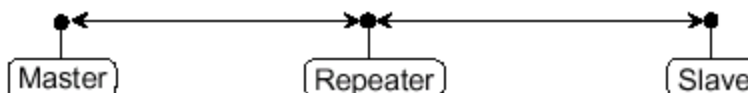

The example below shows a link with two Repeaters between the Master and Slave. With two Repeaters there is more flexibility in getting around obstacles and greater total range is possible. Again, it may be desirable to use external Omni-directional antennas with the Repeaters, and attaching a Yagi to the Master and Slave to increase the range of the link.

When two Repeaters are used no further degradation in the RF throughput of the link is experienced.

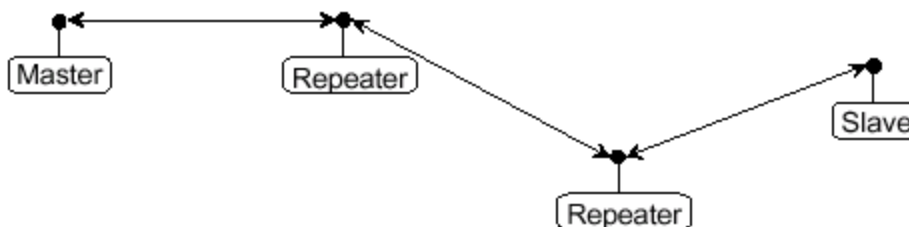

The example below shows a configuration where a Master routinely calls a number of Slaves at different times. The Master is communicating with a transceiver designated as a Slave/Repeater that is connected to a remote device. Since this device is placed in an elevated location, the transceiver may also be used as a Repeater when it is not used as a Slave. At any time the Master may call any of the Slaves, establish a connection, and send and receive data.

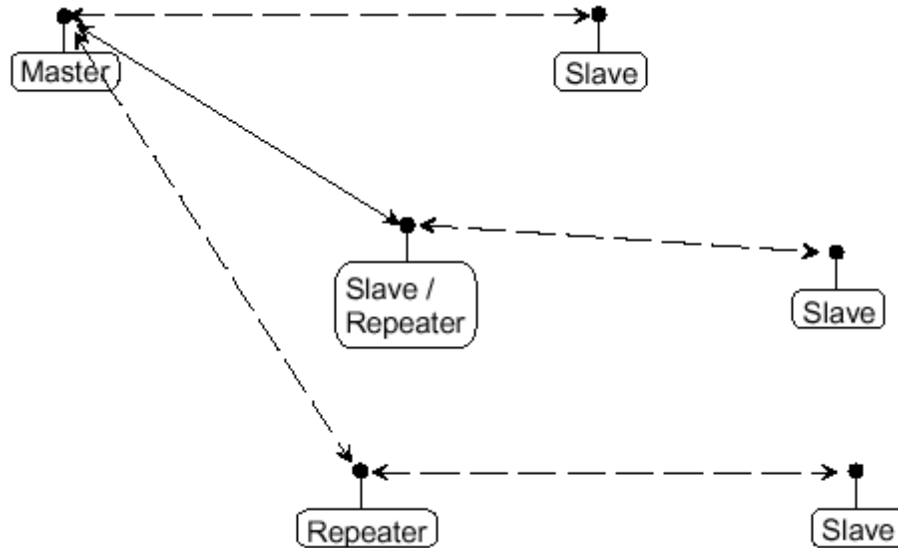

The next example illustrates a standard Point-to-MultiPoint network. From the Master, any data is broadcast to all three Slaves, one of which receives it through a MultiPoint Repeater. The data is in turn sent out of the serial port of each of the three Slaves. The end device should be configured to interpret the serial message and act on it if necessary.

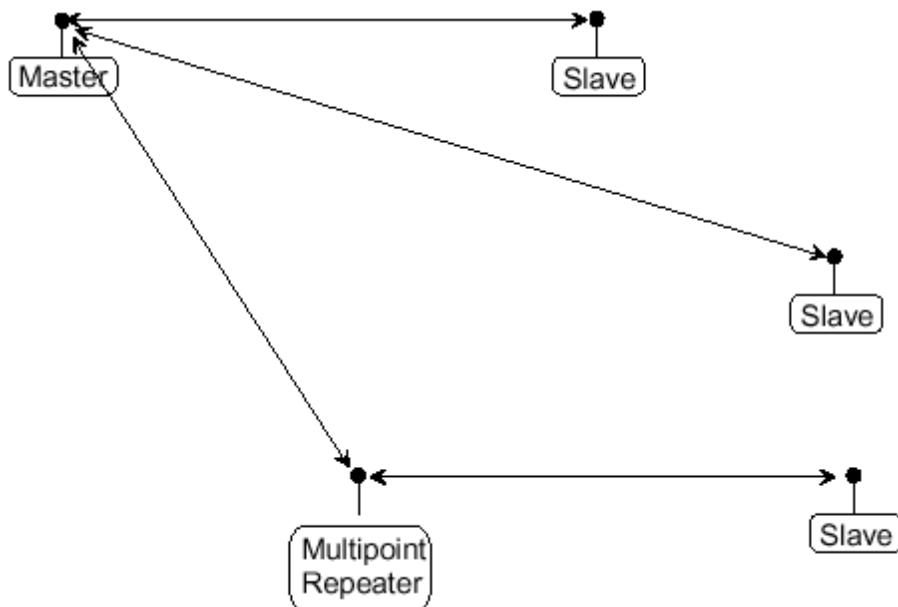

The last example is a Point-to-MultiPoint network that uses one of the sites as a Slave/Repeater. This network functions in the same manner as a standard MultiPoint network with Repeaters. However, the number of radios may be reduced with the use of the MultiPoint Slave/Repeater feature.

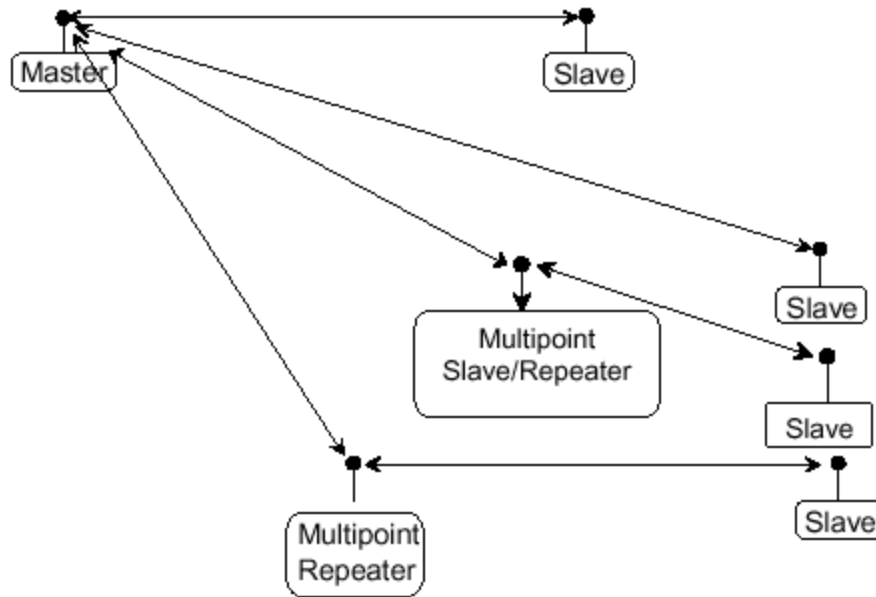

## Finding the Product Serial Number

Each FreeWave transceiver is assigned a unique serial number. If you need to contact FreeWave Technical Support, you will be asked for the serial number on the transceiver you are calling about.

The serial number is three digits, followed by a hyphen and four digits, for example 111-1111, and is printed on the FreeWave label on the transceiver. The example below is for a GXM model; however, the serial number information will be in the same location on different models.

The serial number displays on the label found on the radio.



\* Sample label for GXM-T24 model. The label on your radio contains the correct model number and may contain additional information including regulatory IDs.

On transceivers that are not in an enclosure, you can also find the serial number printed on a label on the back (the flat, smooth side) of the transceiver. This label is in larger print.

On board-level radios, the serial number is also on the back side of the radio, in larger print.



## Identifying Your Transceiver Model

This manual covers the configuration settings for the MM2-T, MM2-LV-T, MM2-MR-R, and MM2-MR-T models. There are slight differences in some of the settings for each model, and important differences in the power requirements between models. Each of these differences is described in detail where they apply throughout this manual.

To identify your transceiver model, look at the following components:

- **Model number on the label** - The model number is printed on the FreeWave label on the transceiver.
- **Connector** - The serial connector on the transceiver helps to identify the model you have.
  - If the connector has 14 pins, your radio is an MM2-T or MM2-LV-T.
  - If the connector has 10 pins, your radio is an MM2-MR-R or MM2-MR-T.
- **Radio size** - The MM2-T and MM2-LV-T models are the smaller of the two radios, at 2 inches x 1.4 inches (50.8 mm x 36 mm).

The MM2-MR-R and MM2-MR-T models are larger, at 2.75 inches x 2.4 inches (70 mm x 62 mm).  
The MM2-MR-R and MM2-MR-T models have a larger interface board (see below).

The following radio is an MM2-T (the image is not to scale):



The following radio is an MM2-M2-R, without its label (image is not to scale):

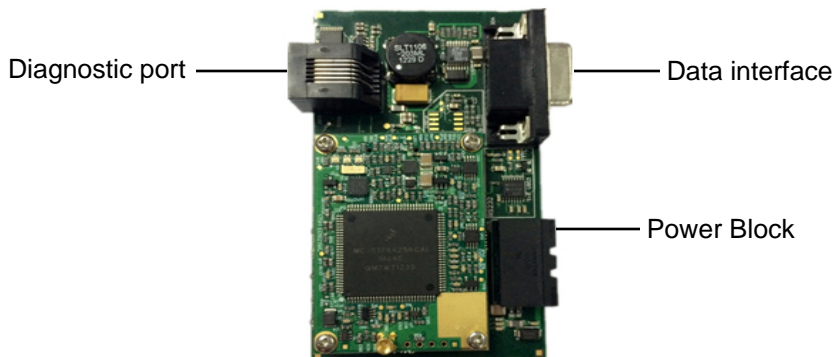

## Powering the Transceiver

To provide power to the transceiver, connect it to a positive power supply with +5.0 VDC for MM2-T models; +3.5 VDC ( $\pm 5\%$ ) for MM2-LV-T models; and +6.0 to +30 VDC for MM2-MR models.

To provide power to the transceiver, connect it to a positive power supply with +6.0 to +30.0 VDC, typically +12.0 VDC.

---

**Important:** FGR2 transceivers are UL approved for use between +6.0 to +30.0 VDC. However, for guaranteed performance, FreeWave recommends using between +7.5 to +30.0 VDC to power the transceiver.

---

Using a dedicated power supply line is preferred. The power supply you use must provide more current than the amount of current drain listed in the specifications for the product and voltage you are using. For example, if you are using +12.0 VDC, the power supply must provide above the drain that is required for transmit as listed in the specifications.



**Warning!** If the power supply is above approximately +18.0 to +20.0 VDC, use a 1 ohm resistor inline with B+ input to the transceiver. For more information about pinouts, see "RF Board Level Pinout" on page 81.

---

If the power supply line runs outside the radio enclosure, use electrostatic discharge (ESD) protectors to protect the radio from electric shock, and transient voltage suppressors (TVS) to protect from an over-voltage situation. Using both helps to ensure long-term, reliable operation. FreeWave does not supply these items; however, they can be purchased at most electronic supply stores.

## Configuration Tool Options

**Note:** The terms modem and transceiver are used interchangeably in this document and in the text within the setup tools. While the words have different meanings, the two terms should be treated as one and the same when referring to FreeWave products.

When the transceiver is in Setup mode, you can use the following setup tools to configure the settings on the transceiver:

- **Tool Suite** - Tool Suite is the newest configuration software and replaces EZConfig, and is the recommended method for programming your transceivers.

It provides a group of tools for configuring the devices in your network and for monitoring your network's performance. Using the Configuration application within Tool Suite, you can program changes to your transceiver's settings. Tool Suite is available on the *User Manual and System Tools* CD and is also available for download from [www.freewave.com](http://www.freewave.com).

For more information about using Tool Suite, see the *Tool Suite User Manual* available on the *User Manual and System Tools* CD or by selecting **File > Help** in the Tool Suite software.

- **Terminal Emulator** - A terminal emulator program, such as HyperTerminal or Tera Term, offers many of the same configuration options that are available in the Configuration application in Tool Suite. Terminal emulators vary in cost, and several are downloadable free of charge. If you run versions of the Windows operating system prior to Windows 7, HyperTerminal is included in the operating system installation. However, if you are run Windows 7 or newer, HyperTerminal is no longer available.

You can use the terminal emulator program of your choice to program the transceiver. The Setup Terminal application within Tool Suite provides the same interface that is available using a terminal emulator.

You can also still use EZConfig to program your older transceiver models; however, Tool Suite is the recommended programming option. Newer transceiver models and newer firmware versions are not available in EZConfig.

## Tool Suite and Terminal Emulators

If you are using a terminal emulator, the tabs for a device in Tool Suite mirror the Setup main menu selections. For example, option **0** from the Setup main menu in the terminal menu setup is **Set Operation Mode**. The corresponding configuration tab for the device in Tool Suite is **(0) Operation Mode**.

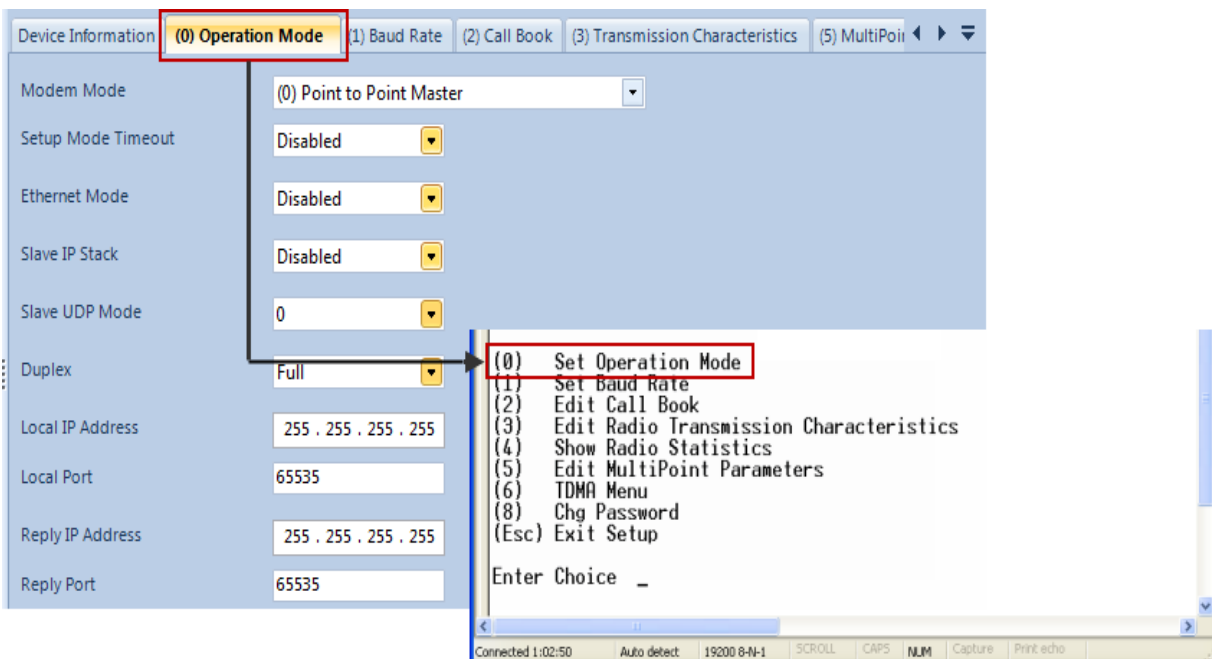



You can also use the Setup Terminal application within Tool Suite to use and view the terminal menus. It displays the same menus and provides the same programming settings as you see using a terminal emulator.

Throughout this document, if the setup procedure in the terminal emulator is different than the procedure in Tool Suite, the terminal instructions are also included.

## Transceiver Setup Mode

To read the current settings from or to program a transceiver, the transceiver must be in Setup mode. When a transceiver is in Setup mode, all three LEDs display solid green ■ ■ ■. See the sections below for details about how to access the transceiver's Setup mode using Tool Suite or a terminal emulator.

**Note:** OEM boards may also enter Setup when Pin 2 is grounded, or using a break command. For more information about the break command, see "Use Break to Access Setup" on page 23.

The **Setup Port** parameter in the Baud Rate tab determines whether the main data port or the diagnostics port is used to access the setup parameters for the transceiver. For more information, see "Setup Port" on page 22.

Using the **Setup Mode Timeout** parameter in the Operation Mode tab, you can set the transceiver to exit Setup Mode automatically. When the setting is enabled, if the transceiver has not received any menu selections or programming information within 5 seconds, it exits Setup and resumes its previous mode.

For Setup mode troubleshooting information, see "Troubleshooting" on page 73.

## Using Tool Suite to Connect to and Program Transceivers

To read and program a transceiver using Tool Suite, you need to connect the transceiver to a computer that runs the Tool Suite software. You can also use Tool Suite to set up a template version of a transceiver. Templates include settings that apply to more than one transceiver in your network. For more information about using templates, see the *Tool Suite User Manual* available from the **File > Help** menu within the application.

1. Connect a serial or diagnostic cable between the computer or laptop and the transceiver.  
Using a diagnostic cable and the diagnostic port is recommended.
2. Connect the power supply to the transceiver and the power source and turn on the transceiver.
3. With the transceiver is connected to the computer in Tool Suite, click **Configuration** in the Application pane to display the Configuration application.
4. Ensure the correct port is selected in the **Com Port** field in the Configuration ribbon.
5. Place the transceiver in Setup mode by pressing the Setup button on the back of the FreeWave transceiver.

If you are connected to the diagnostics port, the transceiver changes to Setup mode automatically when you click **Read Radio** in Tool Suite.



- Short Pin 2 on the header next to the LEDs to ground.

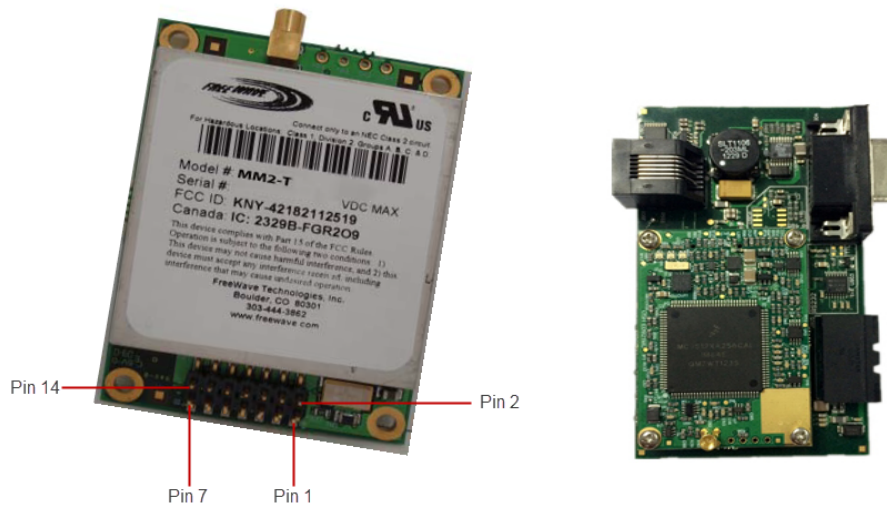

To place a board-level transceiver into Setup mode:

- If using a data cable (FreeWave part number: ASC3610DB or ASC3610DJ), press the Setup button on the data cable.

If you are using Setup Terminal or HyperTerminal and using the gray ribbon diagnostic cable (part number: AC2009DC), or the black diagnostic cable (part number: ASC0409DC), the transceiver changes to Setup mode automatically when you click **Read Radio** in Tool Suite.

All three LEDs on the transceiver light green ■ ■ ■ and stay green as long as the transceiver is in Setup mode.

6. Click **Read Radio** in the Configuration ribbon to read the transceiver's current settings.
7. Make the necessary parameter changes and do one of the following to send the changes to the transceiver:
  - To send only the parameters you have changed, within the Configuration application in the Network Title ribbon, click **Quick**. This option is only available if you clicked **Read Radio** and are not sending parameter settings from a template to the transceiver.
  - To send all the settings for all parameters, within the Configuration application in the Network Title ribbon, click **All**.

- To set a device back to its factory default settings, within the Configuration application in the Network Title ribbon, click **Default**.

For more information about using Tool Suite, see the *Tool Suite User Manual* available on the *User Manual and System Tools* CD or by selecting **File > Help** in the Tool Suite software.

## Accessing the Setup Menu Using a Terminal Emulator

This section provides the steps to access the transceiver setup menu using HyperTerminal. You can use a terminal emulator of your choice. The setup is similar in that you need to tell the emulator to which Com port the transceiver is connected, entering the proper port settings, and setting the transceiver into Setup mode after the connection is established.

**Note:** The screen shots in the following sections represent HyperTerminal in Windows XP. The display may vary slightly if you are using a different operating system.

1. Click the Windows Start button and select **Programs > Accessories > Communications**, and then **HyperTerminal**.

A window similar to the following displays:



2. Double-click the **Hyperterm.exe** icon.

The following window displays:

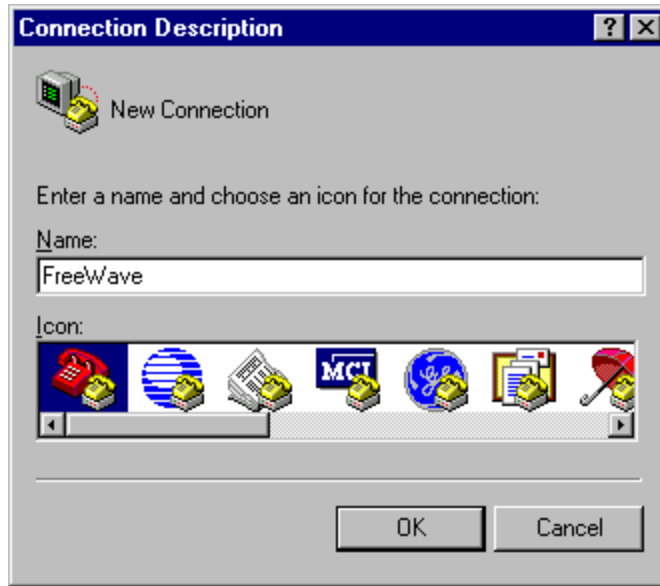

3. In the **Name** field, enter a descriptive name for the connection and select an icon from the Icon selection box.
4. Click **OK**.

The Connect To dialog box displays.



5. In the **Connect Using** field, select the connection type to use.  
Select the active Com Port to which the radio is connected. In most cases the connection type will be either **Direct to Com1** or **Direct to COM2**.
6. Click **OK**.  
The Properties dialog box displays for the selected connection type.

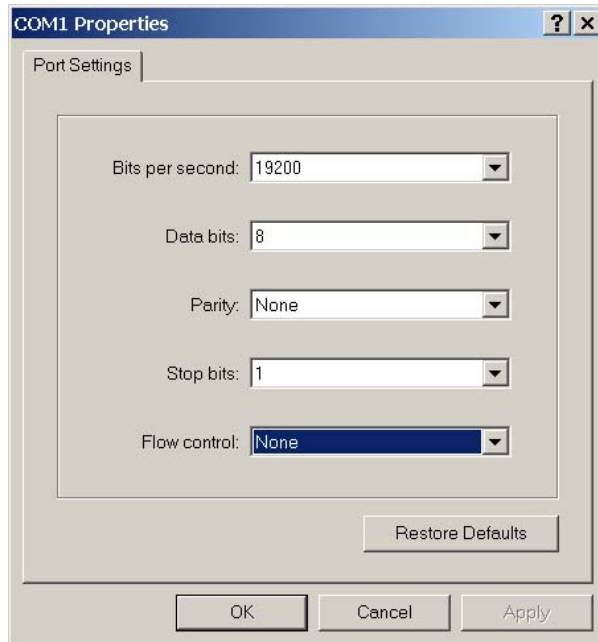

Enter the following port settings for a proper connection:

Port Setting	Select
Bits per second	19200
Data bits	8
Parity	None
Stop bits	1
Flow control	None

- After selecting the option for each setting, click **OK**.

The following HyperTerminal dialog box displays:

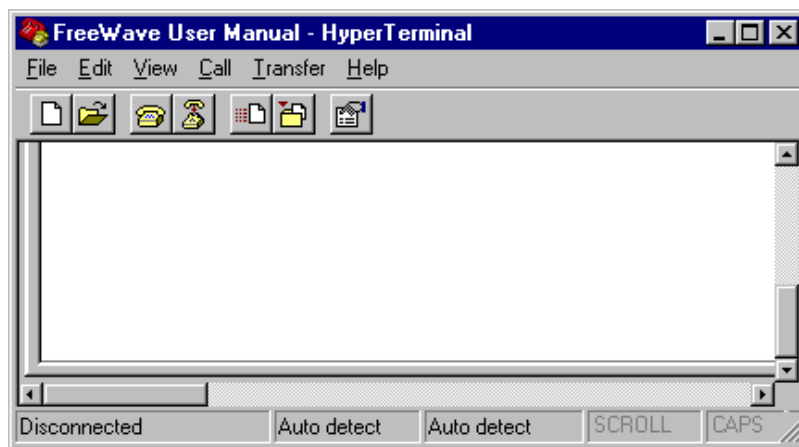

- From the **File** menu, select **Save** to save the HyperTerminal connection settings.

**Important:** To make changes to the connection properties, you must first disconnect the terminal session.

- To connect HyperTerminal to the transceiver, press the Setup button on the back of the FreeWave transceiver. If connected to the diagnostics port, type **U** (Capital 'U') to invoke the Setup menu.



- Place the transceiver in Setup mode.
  - Short Pin 2 on the header next to the LEDs to ground.

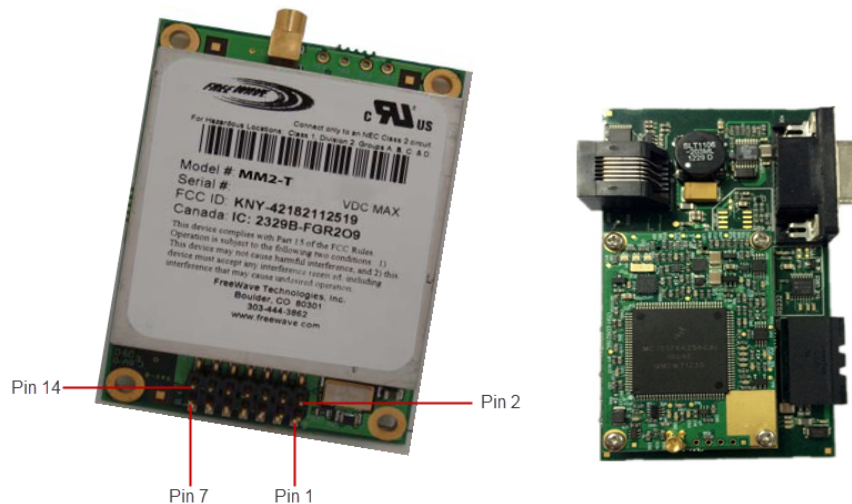

To display the Setup menu in board level radios:

- If you are using a data cable (P/N ASC3610DB or ASC3610DJ), press the Setup button. If using the gray ribbon diagnostic cable (P/N AC2009DC), or the black diagnostic cable (P/N ASC0409DC), press **Shift-U** (capital U) to invoke the Setup menu.

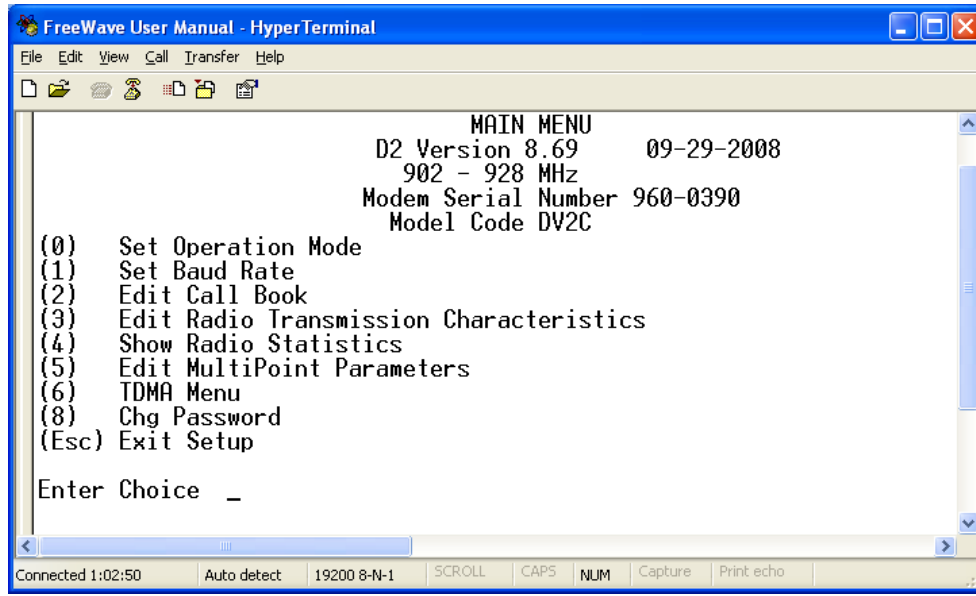

When Setup is invoked, the FreeWave Setup Main Menu displays in the HyperTerminal dialog box. All three LEDs on the transceiver light green ■ ■ ■ and stay green as long as the transceiver is in Setup mode.



As you navigate through the Setup menu and make changes to the parameters, the parameters are sent to the transceiver *immediately*.

## Connecting and Disconnecting from HyperTerminal

The HyperTerminal dialog box displays several icons in the toolbar. To reconnect to HyperTerminal, you need

to disconnect your current session. Click the **Disconnect**  icon, and then click the **Call**  icon to reconnect. If the settings have not been saved they must be re-selected when HyperTerminal reconnects to the transceiver.

## Troubleshooting HyperTerminal

The following are some common issues encountered while using HyperTerminal.

---

**Important:** When a change is made to the HyperTerminal settings in an open terminal sessions, the connection must be disconnected then reconnected before the settings take effect.

---

### Nothing displays on the screen after placing the transceiver into Setup mode.

This usually indicates one of two things; either the wrong COM port is selected or a null modem cable is being used. Follow the steps below to change the COM ports.

1. Click the **Disconnect** icon.
2. From the **File** menu, select **Properties**.
3. Click the **Connect To** tab and verify that the correct COM port is selected.
4. Click **OK** to close the Properties dialog box.
5. Click the **Call** icon.
6. Return the transceiver to Setup mode. The Setup menu screen displays.

In addition, if the radio has been previously configured, you could be using the wrong port to access the Setup menu. For more information, see "Setup Port" on page 22. Try connecting to the other port.

**Gibberish displays on the screen after placing the transceiver into Setup mode.**

This usually indicates a Baud Rate problem. Follow the steps below to change the Baud Rate. The problem may also be that the transceiver under test is a TTL version or has been set to RS485 and not RS232. If the radio is TTL or in RS485 mode, ensure that you are connected through the Diagnostic port. Gibberish before the Setup button is pressed indicates Diagnostics is enabled in a Master.

1. Click the **Disconnect** icon.
2. From the **File** menu, select **Properties**.
3. Click **Configure**, change the following and click **OK**:
  - **Baud Rate** to **19200**
  - **Data Bits** to **8**
  - **Parity** to **None**
  - **Stop Bits** to **1**
  - **Flow Control** to **1**
4. Click **OK** to close the Properties dialog box.
5. Click the **Call** icon.
6. Return the transceiver to Setup mode. The Setup menu screen displays.

**The Setup menu displays on the screen, but nothing happens when keys on the keyboard are pressed.**

This usually indicates flow control is turned on in a three-wire connection (Rx, Tx, and Gnd). Follow the steps below if the connection uses a three-wire connection.

1. Click the **Disconnect** icon.
2. From the **File** menu, select **Properties**.
3. Click **Configure**, change the **Flow Control** to **None**, and click **OK**.
4. Click **OK** to close the Properties dialog box.
5. Click the **Call** icon.
6. Return the transceiver to Setup mode. The Setup menu screen displays.

**A connection exists, HyperTerminal is receiving data, and some data is correct, but the remaining data is in unrecognizable characters.**

This usually indicates a parity mismatch. To resolve this issue, ensure that the parity of the transceiver and the parity of HyperTerminal are set the same. HyperTerminal's parity settings are under Properties and the FreeWave parity is found under the Baud Rate in the Setup menu.

1. Click the **Disconnect** icon.
2. From the **File** menu, select **Properties**.
3. Click **Configure**, change the **Parity** to **None**, and click **OK**.

4. Click **OK** button to close the Properties dialog box.
5. Click the **Call** icon.
6. Return the transceiver to Setup mode. The Setup menu screen displays.

## Upgrading Transceivers to the Latest Firmware

If Tool Suite is connected to a transceiver, and a new version of the firmware is available for that transceiver model, an indication displays within the Configuration application's Device Information tab. You can use Tool Suite to upgrade firmware on a serial transceiver that is connected directly to the computer using the diagnostic cable. You cannot complete an over-the-air upgrade using Tool Suite.

**Note:** If you are using a USB-to-serial converter cable, a firmware upgrade can take a long time to complete. FreeWave recommends using only USB-to-serial cables that include the FTDI Chip Set. This inclusion is listed on the cable's packaging.

For more information about using Tool Suite, see the *Tool Suite User Manual* available on the *User Manual and System Tools* CD or by selecting **File > Help** in the Tool Suite software.

Use the steps below to upgrade a transceiver to the latest firmware:

1. With the transceiver connected to your computer through the Com port, open Tool Suite and click **Configuration** in the Applications pane to display the Configuration application.
2. Click **Upgrade Radio** in the Firmware section of the Configuration ribbon.
3. Click **Yes** at the prompt to proceed or **No** to cancel without installing the new firmware.

Tool Suite identifies and displays the firmware version that is loaded on the connected device and displays the latest version of firmware available for that model.

4. Click **Yes** to proceed with the upgrade, or **No** to exit.

The system displays the progress of the firmware upgrade. After the firmware upgrade is complete, a message displays that the firmware upgrade was successful.

---

## Chapter 2: Basic Transceiver Programming and Setup

---

As you set up your network, whether it be a Point-to-MultiPoint network or a Point-to-Point network, the process for setting up and programming a transceiver is the same. This chapter describes the following aspects of programming and setting up a transceiver, regardless of the network type:

- Setting the transceiver's role in the network, and the network type.
- Entering parameters that establish communication with the instrument or computer to which the transceiver is connected.
- Establishing communication with other transceivers in the network.
- Setting RF transmission characteristics.

### Setting the Transceiver's Role in the Network and the Network Type

Radio networks consist of a Master and any number of other components including Repeaters, Slaves, and transceiver's that act as both a Slave and a Repeater. The first parameter to set in a transceiver is to select its Operation Mode or Modem Mode. The mode tells the transceiver what network type it is in (Point-to-Point or Point-to-MultiPoint) and what role it plays, Master, Slave, Repeater, etc. in that network.

**Note:** The network type must match for all transceivers in a network. For example, if you are configuring a Point-to-MultiPoint network, ensure the **Modem Mode** selection for transceivers in the network starts with Point-to-MultiPoint (options **2, 3, and 7**).

In a Point-to-Point configuration, Master or Slave mode may be used on either end of the communication link without performance degradation. When setting up the transceiver, remember that the Master's settings control a number of parameters. Therefore, deploying the Master on the communications end where it is easier to access is advised, but not necessary.

Set the Modem Mode in the Operation Mode tab, using the **Modem Mode** field. These settings are available in the Operation Mode menu in the terminal interface. Select from the following options:

Operation Mode	Description
<p><b>Point-to-Point Master (0)</b></p>	<p>This mode designates the transceiver as the Master in Point-to-Point mode. The Master may call any or all Slaves designated in its Call Book.</p> <p>In Point-to-Point mode the Master determines the setting used for most of the radio transmission characteristics, regardless of the settings in the Slave and/or Repeaters. The settings not determined by the Master are:</p> <ul style="list-style-type: none"> <li>• RF Xmit Power</li> <li>• Slave Security</li> <li>• Retry Time Out</li> <li>• Hop Table settings</li> </ul> <p>A quick method of identifying a Master is to power the transceiver. Prior to establishing a communication link with a Slave, all three of the Master's LEDs are solid red.</p>
<p><b>Point-to-Point Slave (1)</b></p>	<p>This mode designates the transceiver as a Slave in Point-to-Point mode. The Slave communicates with any Master in its Call Book—either directly or through up to four Repeaters.</p> <p>When functioning as a Slave, the Entry to Call feature in the transceiver's Call Book is not operational. Set <b>Slave Security</b> to <b>1</b> to bypass the Call Book in the Slave. For more information, see "Slave Security" on page 35.</p>
<p><b>Point-to-MultiPoint Master (2)</b></p>	<p>This mode designates the transceiver as a Master in MultiPoint mode. This mode allows one Master transceiver to communicate simultaneously with numerous Slaves and Repeaters.</p> <p>A Point-to-MultiPoint Master communicates only with other transceivers designated as Point-to-MultiPoint Slaves or Point-to-MultiPoint Repeaters.</p>
<p><b>Point-to-MultiPoint Slave (3)</b></p>	<p>This mode designates the transceiver as a Slave in MultiPoint mode. This mode allows the Slave to communicate with a MultiPoint Master. The Slave may communicate with its Master through one or more Repeaters.</p>
<p><b>Point-to-Point Slave/Repeater (4)</b></p>	<p>This mode designates the transceiver to act as <i>either</i> a Slave or Repeater—depending on the instructions from the Master. The transceiver cannot act as both a Slave and a Repeater at the same time. True Slave/Repeater functionality is only available in a MultiPoint mode.</p> <p>Adding a Repeater to a network cuts the network throughput by 50%.</p> <p><b>Note:</b> Point-to-Point Slave/Repeaters have no security features. When a transceiver is designated a Point-to-Point Slave/Repeater, it allows any Master to use it as a Repeater.</p>

Operation Mode	Description
<b>Point-to-Point Repeater (5)</b>	FreeWave allows the use of up to four Repeaters in a Point-to-Point communications link, significantly extending the operating range. When designated as a Repeater, a transceiver behaves as a pass-through link. All settings for the Call Book, baud rates, and radio transmission characteristics are disabled. A Repeater connects with any Master that calls it. The Repeater must be set up properly in the Master's Call Book.  Adding a Repeater to a network cuts the network throughput by 50%.
<b>Point-to-Point Slave/Master Switchable (6)</b>	Mode 6 allows the transceiver to be controlled entirely through software commands. A number of key parameters in the FreeWave user interface may be changed either directly with a program such as Windows Terminal or through the use of script files. Additionally, when the <b>Point-to-Point Slave/Master Switchable</b> option is selected and the transceiver is not calling a Slave, it functions as a Slave and accepts any appropriate calls from other transceivers.  For more information, see application note #5476, <i>Mode 6</i> .
<b>Point-to-MultiPoint Repeater (7)</b>	This option allows the transceiver to operate as a Repeater in a MultiPoint network. You can have as many Repeaters as necessary in a MultiPoint network. If the Repeater is to act as a Slave/Repeater, also set the <b>Slave Repeater</b> parameter in the MultiPoint Parameters tab to <b>Enabled</b> .  Adding a Repeater to a network cuts the network throughput by 50%.
<b>Mirrorbit Master (A)</b>	For information about Mirrored Bit Communication, see FreeWave application note #5424, <i>Using the FGR-115MB Radio with Schweitzer Engineering Labs Mirrored Bits Communications and the FGR Radio Modem in Mirrored Bit Mode Addendum</i> .  Mirrored Bit Communication is supported in firmware version 8.77 and later.
<b>Mirrorbit Slave (B)</b>	
<b>Ethernet Options (F)</b>	This menu is needed for Ethernet transceivers only. Although the menu is included here, it is unrelated to this transceiver.

## Establishing Communication with Instrumentation and Computers

The settings in the Baud Rate tab are the communication settings between the transceiver and the instrument or computer to which it is connected (transceiver serial port to the device). These settings are unique to each transceiver, and do not need to match across the network.

For example, a pair of transceivers may be used in an application to send data from remote process instrumentation to an engineer's computer. In this application, the baud rate for the transceiver on the instrumentation might be set to 9600, and the transceiver on the polling host might be set to 57,600.

Set the following parameters in the Baud Rate tab. These settings are available in the Baud Rate menu in the terminal interface, and apply to both Point-to-Point and Point-to-MultiPoint networks.

## Baud Rate

- Default Setting: 115200
- Options: 600, 1200, 2400, 4800, 9600, 19200, 38400, 57600, 76800, 115200, 230400
- Setup Terminal Menu: (1) Set Baud Rate
- Description: The communication rate between the transceiver's data port and the instrument to which it is connected. This setting is independent from the baud rate for the other transceivers in the network. Set the baud rate to the highest level supported by the device to which it is connected. With a poor radio link, however, this may actually result in slower data communications.
- With a **Baud Rate** setting of 38,400 or higher, FreeWave recommends that you use the Flow Control lines.
- Note:** The Setup port baud rate always defaults to **19,200** no matter how the data port Baud Rate is set. The only exception is Mode 6. For more information, see application note #5476, *Mode 6*.

## Data Parity

- Default Setting: 0 (8, N, 1)
- Options: See table below.
- Setup Terminal Menu: (1) Set Baud Rate > (A) Data Parity
- Description: Six data word length and parity configurations are available for use with FreeWave transceivers. The default setting is **8-None-1** and is the most commonly used serial communications protocol.
- The following table describes each option:

Option	Data Bits	Parity	Stop Bits
0	8	None	1
1	7	Even	1
2	7	Odd	1
3	8	None	2
4	8	Even	1
5	8	Odd	1

## Flow Control

- Default Setting: (0) None
- Options:
  - **(0) None** - No flow control CTS is active and de-asserts when buffering is 98% full. Can pass XON/XOFF data but does not use it in any way.

- **(1) RTS** - Uses standard RTS/CTS control lines.
- **(2) DTR**

Setup Terminal Menu: (2) Set Baud Rate > (F) FlowControl

Description: Specifies the hardware flow control for the data port on the transceiver. FreeWave recommends using **Flow Control** if you are using a baud rate higher than 19200.

## Modbus RTU

**Note:** When using the transceiver in **Modbus RTU** mode, the **Master Packet Repeat** setting in the MultiPoint Parameters tab must match in every transceiver, regardless of whether the network is in Point-to-Point or MultiPoint mode. The **Modbus RTU** mode must be set to **1** when transceivers are configured in RS485 or RS422 mode.

Default Setting: 0 (Disabled)

Options: 0 to 9

Setup Terminal Menu: (1) Set Baud Rate > (B) Modbus RTU

Description: A setting other than **0** in this parameter causes the transceiver to wait for an amount of time “gathering” data before sending out the radio link.

- **0 (Disabled)** - The transceiver sends data out through its radio link as soon as the data is received into the serial port. This is the default setting.
- **1** - The transceiver waits for a number of slots equal to two times the **Master Packet Repeat** setting before sending the received data out the radio link. For example, if the **Master Packet Repeat** parameter is set to **3**, the transceiver waits for 6 slots, gathering data up the whole time. At the end of the 6 slots, the transceiver sends all received data in one “burst.” This is the appropriate setting for most Modbus RTU devices.
- **2 or higher** - The transceiver waits for a number of slots calculated using the following formula:

$$(\text{Modbus RTU setting} + \text{Master Packet Repeat setting} + 1) \times 2$$

For example, in a transceiver where the **Modbus RTU** setting is **2** and the **Master Packet Repeat** setting is **3**, the transceiver waits for  $(2 + 3 + 1) \times 2$ , or 12 slots.

## Serial Interface

Default Setting: (0) RS232

- Options:
- **(0) RS232** - Also used for TTL.
  - **(1) RS422/Full Duplex RS485** - **Modbus RTU** mode must be enabled and **Turn Off Delay** set to at least **4**.
  - **(2) Half Duplex RS485** - **Modbus RTU** mode must be enabled and **Turn**

**Off Delay** set to at least **4**.

- **(3) DOT** - DOT causes the CD line to indicate when data is transmitted on the serial port from the transceiver. When the transceiver is not sending data to the serial port, CD is de-asserted. When the transceiver is sending data to the serial port, CD is asserted. The CD line no longer has any radio link state functionality. **Turn Off Delay** works as described in all radios. **Turn On Delay** works as described on any Slave or Slave/Repeater - it has no functionality on the Master.

If set to anything other than **0**, the **Setup Port** parameter in the Baud Rate tab must be set to **Diagnostics Only**.

Setup Terminal Menu: (1) Set Baud Rate > (C) RS232/485

Description: Use this option to set the protocol of the data port. This setting must be **0** in TTL RF board products (FGR2-T,MM2-T,MM2-LV-T,MM2-MR-T.)

## Setup Port

---

**Important:** Do not change this setting unless the correct programming cable is available for the new setting.

---

Default Setting: (3) Both

The factory setting is based on the transceiver type. A setting of **2** is used with Ethernet products and Mirrored Bit products, a setting of **3** is used otherwise.

- Options:
- **(1) Main Only** - Programming and reading a transceiver's setup information is done through the data port.
  - **(2) Diagnostics Only** - Programming and reading a transceiver's setup information is done through the diagnostic port. If the **Serial interface** is set to anything other than RS232, then the **Setup Port** must be set to **Diagnostics Only**.
  - **(3) Both** - Programming and reading a transceiver's setup information is done through either the data port or the diagnostic port .

Setup Terminal Menu: (1) Set Baud Rate > (D) Setup Port

Description: Determines which port on the transceiver, Main or Diagnostics, is used to access the parameter settings in Tool Suite or enter the Setup main menu in the terminal interface.

The main data port is the RS232 port. The diagnostics port is a 3-pin connector on the rear panel of the OEM "Mini" series transceivers. The diagnostic cable for this port (ASC0409DC) is available from FreeWave. The OEM modules use a 2-row, 2 mm female connector. The diagnostic cable for this port (ASC2009DC) is available from FreeWave.

## Turn Off Delay

**Note:** The MM2 radios do not use the **Turn Off Delay** parameter.

Default Setting:	0
Options:	Any number between 0 and 9 ms.
Setup Terminal Menu:	(1) Edit Baud Rate > Turn Off Delay
Description:	<p>Specifies the time after the end of transmission of a character to the RS485 bus that the transceiver stops driving the bus and releases the bus to other devices. The units are <math>\frac{1}{4}</math> of a character with a range of 0-9. An entry of 4 means a delay equivalent to the duration of a full character. The default is zero delay.</p> <p>For data rates of 1200 bits/S or slower, avoid setting the <b>Turn Off Delay</b> parameter higher than <b>4</b>. At those rates the functionality of the microprocessor changes so that a <b>Turn Off Delay</b> of <b>5</b> has the same effect as if set to <b>1</b>, and a setting of <b>6</b> has the same effect as <b>2</b>, and so on.</p> <p><b>Note: Turn Off Delay</b> must be set to a value of at least <b>4</b> for RS422 and RS485 operation.</p>

## Turn On Delay

Default Setting:	0 mS
Options:	Any number between 0 and 9 mS
Setup Terminal Menu:	(1) Set Baud Rate > (E) Turn On Delay
Description:	Sets the delay between when the line drivers are turned on and when the data leaves the data port.

## Use Break to Access Setup

**Note:** This setting is typically only used in OEM scenarios.

Default Setting:	Disabled
Options:	<ul style="list-style-type: none"> <li>• <b>(0) - Disabled</b> - The break command is disabled in the radio.</li> <li>• <b>(1) - Enabled</b> - The Setup menu is sent at 19200 bps.</li> <li>• <b>(2) - Enabled</b> - The Setup menu is sent at the transceiver's current baud rate. This setting is only available through the terminal interface.</li> </ul>
Setup Terminal Menu:	(2) Set Baud Rate > (G) Use break to access setup
Description:	<p>Enables a break command to put the transceiver into Setup mode over the data port. To send a break character the end device must hold the Tx data line in the space voltage level for longer than 1 character time. If a character is defined as having 1 start bit, 8 data bits, and 1 stop bit, the character time is 10 bits, thus the Tx data line must be held in the space voltage level for a period of time longer than 10 bits.</p>

## Establishing Communication with Other Transceivers in the Network

For the transceivers in your network to communicate successfully, you need to tell the transceivers what other devices are available for them to communicate with. Use one of the following options:

- **Network ID** - Used in MultiPoint Networks, the **Network ID** parameter is available in the MultiPoint Parameters tab. Each transceiver in a single network should be assigned the same network ID. A Slave links with the first Master or Repeater that it hears that has a matching **Network ID**.

Because the **Network ID** does not use serial numbers, MultiPoint Masters and Repeaters may be replaced without reprogramming all of the Slaves in the network. The **Network ID** function should be used in conjunction with the **Subnet ID** feature (if necessary) to route data through the transceiver network.

Without having the serial numbers in the Call Book, Slaves may establish communications with different Masters that match the transceiver's golden settings described below, though not at the same time. This is very useful in mobile MultiPoint applications.

For information about setting the **Network ID** parameter in a MultiPoint Network, see "Using the Network ID in MultiPoint Networks" on page 42.

- **Call Book** - The Call Book is **required** in Point-to-Point networks. The Call Book stores serial numbers of transceivers in the network that are allowed to talk to a transceiver. Using the Call Book offers both security and flexibility in determining how FreeWave transceivers communicate with each other.

---

**Important:** While the Call Book is an option in Point-to-MultiPoint networks, FreeWave strongly recommends using the **Network ID** feature in most applications. If a large MultiPoint network is implemented using the Call Book and you want to add a transceiver to the network, or need to replace a transceiver, you must physically reprogram each radio in the network and enter the new serial number in the transceiver's Call Book. This can be a time consuming process and can cause a delay in getting your network back up and running.

---

For more information about defining the Call Book in a Point-to-Point network, see "Using the Call Book in Point-to-Point Networks" on page 58. For more information about defining the Call Book in a Point-to-MultiPoint network, see "Using the Call Book in MultiPoint Networks" on page 42.

### "Golden Settings"

A standard network requires that the following parameters are set the same on all transceivers in the network. FreeWave refers to these as the "golden" settings.

- **Frequency Key**
- **Min Packet Size**
- **Max Packet Size**
- **Network ID**
- **RF Data Rate**

Transceivers that contain the same settings in all these parameters can communicate with each other. If you choose to use the Call Book instead of the **Network ID**, or are running a Point-to-Point network, the appropriate serial numbers must be listed in the Call Book for each transceiver. If you are working with parallel Repeaters, the **Frequency Key** setting may differ.

## Setting RF Transmission Characteristics

The Transmission Characteristics parameters allow you to modify settings that determine how data is sent between transceivers in your network. Many of these parameters must be maintained throughout the network for proper functionality.

---

**Important:** The parameters in the Transmission Characteristics tab are only for the advanced user who has a good understanding of the principles of RF transmission.

---

Several settings on a Slave or Repeater transceiver come from the Master, and are therefore set **only** at the Master. Settings that you must set on each **Slave or Repeater** include the following:

- Transmit Power
- Slave Security
- Retry Time Out
- Hop Table Size
- Hop Table Version
- Hop Table Offset

You can leave most parameters in the Transmission Characteristics tab set to their default settings when completing basic setup. However, you must set the following parameters, and they **must be the same** for all transceivers in your network:

- Frequency Key
- Hop Table properties (Size, Version, and Offset)
- Max Packet Size
- Min Packet Size
- RF Data Rate

Set the following parameters in the Transmission Characteristics tab. These settings are available in the Edit Radio Transmission Characteristics menu in the terminal interface, and apply to both Point-to-Point and Point-to-MultiPoint networks, unless indicated otherwise in their description.

### Frequency Key (Golden Setting)

**Note:** In MultiPoint networks, the **Frequency Key** must be set identically in all transceivers. Any transceiver with a **Frequency Key** different from the Master will not establish a link. In Point-to-Point networks the Master's settings take precedence over the Slave.

Default Setting: 5  
Options: 0 to 9 and A to E

**Note:** Do not use Frequency Key **E** with the 915-928 MHz, 916-920 MHz,

and 921-928 MHz hop tables.

Setup Terminal Menu: (3) Edit Radio Transmission Characteristics > (0) FreqKey

Description: Fifteen choices are available for the **Frequency Key** setting, representing 15 different pseudo-random hop patterns. Hopping patterns minimize the interference with other FreeWave transceivers operating in the area.

For example, if 10 pairs of FreeWave transceivers are operating on different networks in close proximity, setting a different **Frequency Key** value reduces the chance that transceivers hop to the same frequency at the same time. If two networks were to hop to the same frequency, the next hop would be to a different frequency for both networks.

You can gain additional network separation by adjusting the **Max Packet Size** and **Minimum Packet Size**.

Use the **Hop Table Version**, **Hop Table Size**, and **Frequency Zone** fields to define more network differentiation by way of limiting the number and location of frequencies the transceivers may hop on in the 902-928 MHz band.

**Note:** 900 MHz transceivers do not use the **Hop Frequency Offset** setting.

## Frequency Zones

**Note:** In MultiPoint networks, this setting only needs to be set on the Master. In a Point-to-Point network, the Master and the Slave must have matching **Frequency Zone** settings.

Default Setting: All zones selected

Options: See below.

Setup Terminal Menu: (3) Edit Radio Transmission Characteristics > (0) FreqKey > F >  
(3) Frequency Zone

Description: Divides the available band (902 MHz to 928 MHz) into smaller bands, in this case 16 smaller bands each consisting of 5, 7, and 8 frequency channels depending on the frequency zone. These 16 zones are stored in a Word, which is made up of 16 bits numbered 0 to 15. When displayed in LSB to MSB, these bits directly represent the zones that the transceiver operates on from lowest frequency to highest.

A value of **1** in the bit sequence instructs the transceiver to operate within the represented band. A value of **0** instructs the transceiver to bypass the represented band. This feature should only be used with the standard hop table.

**Note:** You must set the **Hop Table Version** to **902-928 MHz** when using frequency zones. If you select another **Hop Table Version**, the limitations of that selection would be applied to the hopping pattern as well. For example, if you select **916-920** as the **Hop Table Version**, only the middle of the band would be available in the pattern. Then, if frequency zones **5**, **6**, **7**, **8**, and **9** were set to **0**, no allowable frequencies would be available for the transceiver to use.



**Warning!** FCC regulations require a minimum of 50 separate channels be used within a hop pattern. Use the table below to determine the number of frequency zones required for legal communication.

**EXAMPLE:**

1. Using zones 1-7 is equal to 49 channels; this is not legal according to the FCC.
  
2. Using Zones 0-6 is equal to 50 channels; this is legal according to the FCC.

Binary Zone Number (LSB First)	Beginning Freq. (MHz)	Ending Freq. (MHz)	Number Of Channels
1	902.2464	903.8592	8
2	904.0896	905.4720	7
3	905.7024	907.0848	7
4	907.3152	908.6976	7
5	908.9280	910.3104	7
6	910.5408	911.9232	7
7	912.1536	913.5360	7
8	913.7664	915.1488	7
9	915.3792	916.7616	7
10	916.9920	918.6048	8
11	918.8352	920.2176	7
12	920.4480	921.8304	7
13	922.0608	923.4432	7
14	923.6736	925.0560	7
15	925.2864	926.6688	7
16	926.8992	927.8208	5

**To enable Frequency Zones in Tool Suite:**

1. In the Tool Suite Configuration application, select the device to program and click the **(3) Transmission Characteristics** tab.
2. Click **Frequency Zones** in the Transmission Characteristics tab to display the frequency zones available.
3. Select the check boxes next to the Frequency Zones to enable.

**To enable Frequency Zones in the terminal interface:**

1. From the main Setup menu, select **3 Edit Radio Transmission Characteristics**.
2. Select option **0 FreqKey**.

3. Select **F** for More.
4. Select option **3 Frequency Zone**.
5. Enter **1** to enable a frequency zone and **0** to disable a frequency zone. Frequency Zone entries begin with **1** (LSB) and continue through **16** (MSB).

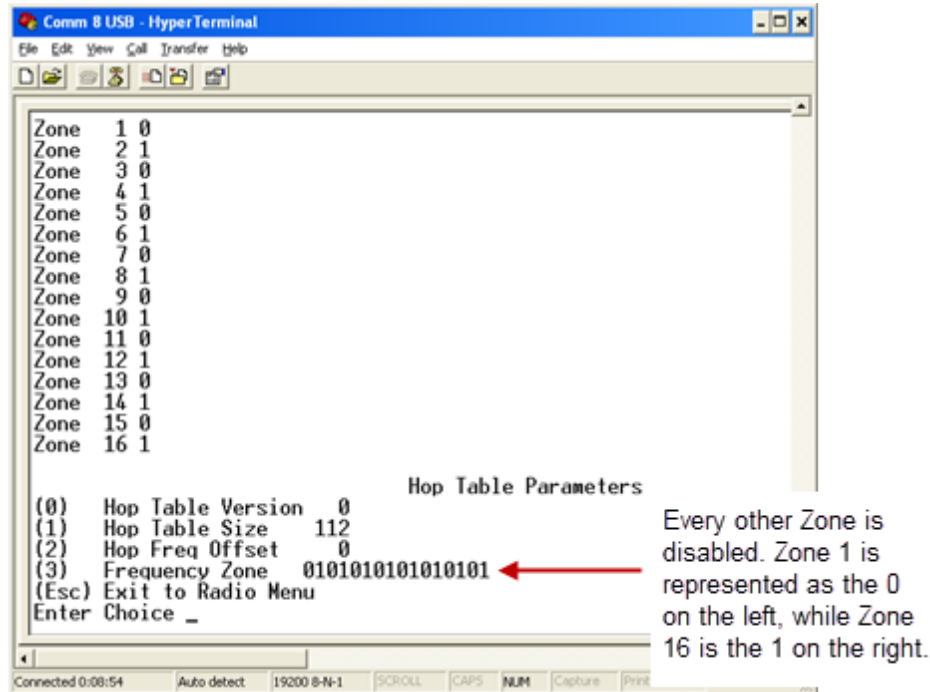

## High Noise

**Note:** The High Noise option is not functional in the MM2 radios.

Default Setting: (0) Disabled

Options: (0) Disabled  
(1) Enabled

Setup Terminal Menu: (3) Edit Radio Transmission Characteristics > (A) High Noise

Description: Use to determine if out-of-band interference is affecting a radio link. A setting of **1** provides a reduction of gain in the front end circuit thereby decreasing the effect of any out-of- band noise. The results are seen as a lower signal value and a much lower noise value (as found in Radio Statistics or Diagnostics). If the noise is not reduced by a greater amount than the signal, the interference is most likely an in-band issue.

When a noise problem is shown to be helped using the **High Noise** option, chances are that the noise may be further decreased using a bandpass filter available from FreeWave.

## Hop Table Size

**Note:** All transceivers in a network must have identical **Hop Table** settings to function properly.

- Default Setting: 112
- Options: 50 to 112
- Setup Terminal Menu: (3) Edit Radio Transmission Characteristics > (0) FreqKey > F > (1) Hop Table Size
- Description: Defines how many separate channels a given network uses.  
FreeWave recommends using **Frequency Zones** instead of the **Hop Table Size** setting.



**Warning!** FCC regulations require a minimum of 50 separate frequency channels be used within a hop pattern. Using the Standard hop table, a minimum of 5 frequency zones are required for legal communication.

## Hop Table Version

**Note:** All transceivers in a network must have identical **Hop Table** settings to function properly.

- Default Setting: 902-928 MHz
- Options:
- 902-928 MHz, full band
  - 921-928 MHz
  - 915-928 MHz
  - 902-911 - 919-928 MHz, uses 902-928 MHz with center frequencies of 911-919 MHz notched out
  - 903.744-926.3232 MHz
  - 902-915 MHz
  - 916-920 MHz

Do not use **Frequency Key E** (916-920 MHz) with the 915-928 MHz, 916-920 MHz, and 921-928 MHz hop tables.

- Setup Terminal Menu: (3) Edit Radio Transmission Characteristics > (0) FreqKey > F > (0) Hop Table Version

- Description: Determines the section of the 900 MHz band the transceiver uses.  
In the terminal interface, enter the number that corresponds to the frequency band:

Number to Enter in Terminal Menu	Frequency Band
0	902-928 MHz, uses the full band
1	915-928 MHz
2	903.744-926.3232 MHz

Number to Enter in Terminal Menu	Frequency Band
3	916-920 MHz
4	921-928 MHz
5	902-911_919-928 MHz, uses 902-928 MHz with center frequencies of 911-919 MHz notched out
6	902-915 MHz

### Max Packet Size and Min Packet Size (Golden Setting)

**Note:** In MultiPoint networks, the **Max Packet Size** and **Min Packet Size** must be set identically in all transceivers. In Point-to-Point networks the Master's settings take precedence over the Slave.

Default Setting: Max Packet Size = 8

Min Packet Size = 9

Options: Any number between 0 and 9.

Setup Terminal Menu: (3) Edit Transmission Characteristics > (1) Max Packet Size and (2) Min Packet Size

Description: The **Max** and **Min Packet Size** settings and the **RF Data Rate** determine the number of bytes in the packets. Throughput can be enhanced when packet sizes are optimized. In Point-to-Point mode, the **Max** and **Min Packet Size** settings do not have material impact on throughput unless 115.2 KBaud is desired. However, this may have an impact on latency. For example, if small amounts of data are sent and large packet sizes are selected, a certain amount of time "wasted" between each packet would be seen.

The following table defines the minimum packet size in bytes by charting the **Min Packet Size** setting versus the **RF Data Rate** setting. Using the default settings, the actual minimum packet size, in bytes, is 44.

Minimum Packet Size Definition		
Min Setting	Min Packet Size RF Data Rate = 2	Min Packet Size RF Data Rate = 3
0	15	8
1	21	12
2	26	16
3	31	20
4	37	24
5	42	28

Minimum Packet Size Definition		
Min Setting	Min Packet Size RF Data Rate = 2	Min Packet Size RF Data Rate = 3
6	47	32
7	53	36
8	58	40
9	63	44

The following table defines the maximum packet size in bytes by charting the **Min Packet Size** setting versus the **Max Packet Size** setting where the **RF Data Rate** is set to **2** (High).

Maximum Packet Size Definition with RF Data Rate of 2										
Minimum Setting	Maximum Setting									
	0	1	2	3	4	5	6	7	8	9
0	15	37	58	79	101	122	143	165	186	207
1	21	42	63	85	106	127	149	170	191	213
2	26	47	69	90	111	133	154	175	197	218
3	31	53	74	95	117	138	159	181	202	223
4	37	58	79	101	122	143	165	186	207	229
5	42	63	85	106	127	149	170	191	213	234
6	47	69	90	111	133	154	175	197	218	239
7	53	74	95	117	138	159	181	202	223	245
8	58	79	101	122	143	165	186	207	229	250
9	63	85	106	127	149	170	191	213	234	255

The following table defines the maximum packet size in bytes by charting the **Min Packet Size** setting versus the **Max Packet Size** setting where the **RF Data Rate** is set to **3** (Normal). Using the default settings, the actual maximum packet size, in bytes, is 172.

Maximum Packet Size Definition with RF Data Rate of 3										
Minimum Setting	Maximum Setting									
	0	1	2	3	4	5	6	7	8	9
0	8	24	40	56	72	88	104	120	136	152
1	12	28	44	60	76	92	108	124	140	156
2	16	32	48	64	80	96	112	128	144	160
3	20	36	52	68	84	100	116	132	148	164
4	24	40	56	72	88	104	120	136	152	168
5	28	44	60	76	92	108	124	140	156	172

Maximum Packet Size Definition with RF Data Rate of 3										
	Maximum Setting									
Minimum Setting	0	1	2	3	4	5	6	7	8	9
6	32	48	64	80	96	112	128	144	160	176
7	36	52	68	84	100	116	132	148	164	180
8	40	56	72	88	104	120	136	152	168	184
9	44	60	76	92	108	124	140	156	172	188

Referencing the default settings, the Master transmits up to 172 bytes on every hop. If fewer than 172 bytes are transmitted, the balance is allocated to the Slave's transmission, plus the quantity in the **Min Packet Size** setting.

For example, if a Master transmits 100 bytes, the Slave then has a total of 116 bytes available:

$$(72 \text{ ("leftover bytes")} + 44 \text{ (Min packet size)})$$

## MCU Speed

**Note:** This feature is not supported in the MM2 transceivers.

Default Setting: (0) Normal

Options:

- **(0) Normal (low speed)** - Reduces current consumption.
- **(1) Fast (high speed)** - Required for 230 Kbaud and greater data port rate.

Setup Terminal Menu: (3) Edit Radio Transmission Characteristics > (B) MCU Speed

Description: Controls the speed of the Micro Controller Unit (MCU) in the transceiver.

## Remote LED

Default Setting: (0) Local Only

Options:

- **(0) Local Only** - Only the LEDs on the radio board are enabled.
- **(1) Remote and Local** - LEDs on the radio board and remote LEDs through the diagnostic port are enabled.
- **(2) Remote Only** - LEDs on the radio board are disabled. Remote LEDs through the diagnostic port are enabled.

Setup Terminal Menu: (3) Edit Radio Transmission Characteristics > (C) Remote LED

Description: If you are using a transceiver with the optional 20-pin connector, you can use this option to connect remote LEDs through the diagnostics port.

This feature may be used to save power in MultiPoint Repeaters. By turning off the on-board LEDs (setting = **2**) the current consumption is reduced. To reduce current consumption in Slaves, use **Low Power** (setting = **1**). Low Power does not work with MultiPoint Repeaters because Repeaters are constantly transmitting. **Remote LED** drives the Diagnostic port, which has a small amount of current draw.

When using remote LEDs, the center (TX) LED does not output a signal for a green LED when in Setup mode. The Green TX LED has no remote pinout.

## Retry Time Out

Default Setting:	255
Options:	Any number between 0 and 255 in MultiPoint networks. Any number between 151 and 255 in Point-to-Point networks.
Setup Terminal Menu:	(3) Edit Transmission Characteristics > (8) Retry Time Out
Description:	<p>The <b>Retry Time Out</b> parameter in a Slave or Repeater sets the delay the unit waits before dropping the connection to a Master or Repeater. The factory default is set at the maximum of <b>255</b>. The maximum setting means that if 1 packet in 255 is sent successfully from the Master to the Slave or Repeater, the link is maintained. The minimum setting is <b>8</b>. This allows a Slave or Repeater to drop a connection if less than 1 in 8 consecutive packets is successfully received from the Master. The function in the Master is effectively the same. With a setting of <b>255</b>, the Master allows a Slave or Repeater to stay connected as long as 1 packet in 255 is successfully received at the Master.</p> <p>The <b>Retry Time Out</b> parameter is useful when a MultiPoint network has a roving Master or Slave(s). As the link gets weaker, a lower setting allows a poor link to break in search of a stronger one.</p> <p><b>Note:</b> Setting <b>Retry Time Out</b> to <b>20</b> in the MultiPoint Master is recommended in areas where several FreeWave networks exist. This recommended setting allows Slaves and Repeaters to drop the connection if the link becomes too weak, while at the same time prevent errant disconnects due to interference from neighboring networks.</p> <p>While intended primarily for MultiPoint networks, the <b>Retry Time Out</b> parameter may also be modified in Point-to-Point networks. However, the value in Point-to-Point mode should not be set to less than 151.</p>

## RF Data Rate (Golden Setting)

**Note:** In MultiPoint networks, the **RF Data Rate** must be set identically in all transceivers. Any transceiver with an **RF Data Rate** different from the Master will not establish a link. In Point-to-Point networks the Master's settings take precedence over the Slave.

Default Setting:	(3) Normal
Options:	<ul style="list-style-type: none"> <li>• (2) High - 154 kbps</li> <li>• (3) Normal - 115.2 kbps</li> </ul>
Setup Terminal Menu:	(3) Edit Transmission Characteristics > (4) RF Data Rate
Description:	FreeWave transceivers have two <b>RF Data Rate</b> settings; <b>2</b> (High) and <b>3</b> (Normal). <b>RF Data Rate</b> should not be confused with the serial port <b>Baud</b>

**Rate.** Use setting **2** (RF Speed of 153.6 kbps) when the transceivers are close together and you need to optimize data throughput. Use setting **3** (RF Speed of 115.2 kbps) when the transceivers are farther away and a solid data link is preferred over data throughput.

## RTS to CTS

**Note:** The **RTS to CTS** option is only available in RS232 mode. It is not recommended to enable this feature when operating at baud rates above 38.4 kB.

Default Setting: (0) Disabled

Options:

- (0) Disabled
- (1) Enabled
- (2) Line Alarm

Setting **2** is described in detail in the application note #5437, *DTR to CTS Line Alarm Feature*.

Setup Terminal Menu: (3) Edit Transmission Characteristics > (7) RTS to CTS

Description: Use this option to set the RTS line on the Master transceiver to control the CTS line of the Slave. In MultiPoint networks, the Master RTS line controls all Slaves' CTS lines. When enabled, the CTS line ceases to function as flow control.

With **RTS to CTS** enabled, the Master senses the RTS line prior to all scheduled packet transmissions. If the state has changed, the Master then transmits a message to the Slave with the new status. This transmission occurs regardless of data being sent. If data is ready to be sent, the RTS status message is sent in addition to the data. In Point-to-Point mode, the Master continues sending the new status message until it receives an acknowledgment from the Slave. In MultiPoint mode, the Master repeats the message the number of times equal to the **Master Packet Repeat** value in the MultiPoint Parameters tab.

Master transmit times are completely asynchronous to the occurrence of any change of the RTS line; the latency time from RTS to CTS is variable. The **Max** and **Min Packet Size** parameters determine this duration. Setting both parameters to their maximum value of **9** produces a maximum latency time of approximately 21 ms, given no Repeaters in the network. At the minimum settings for **Max** and **Min Packet Size (0)**, the time is approximately 5.9 ms. This latency can increase significantly if packets are lost between the Master and Slave. In Point-to-MultiPoint mode, no absolute guarantee is made that the state change is communicated to all Slaves. In MultiPoint networks with Repeaters present, the latency is cumulative for each serial Repeater.

For example, if the latency between the Master and the first Repeater is 15 ms, and two serial Repeaters are present, the total latency is 45 ms. (M—R1 (15 ms) + R1—R2 (15 ms) + R2—S (15 ms) = 45 ms)

**Note:** The **RTS to CTS** feature does not function in Point-to-Point networks that contain a Repeater. If this feature is needed in such network, the mode should be changed to Point-to-MultiPoint.

If **DTR Connect** in the MultiPoint Parameters tab is enabled and set to **2**, the RTS to CTS feature does not work. If **DTR Connect** is enabled and set to **1**, RTS to CTS mode takes precedence over the functionality of the CTS line on the Slave relating to the **DTR Connect** feature.

## Slave Security

**Note:** **Slave Security** has no effect in Point-to-MultiPoint networks where the **Network ID** is used.

Default Setting: (0) On

Options: (0) On  
(1) Off

Setup Terminal Menu: (3) Edit Transmission Characteristics > (6) Slave Security

Description: **Slave Security** allows Slave transceivers to accept transmissions from a Master not included in the Call Book. The default setting of **0** (On) means only Masters in the Slaves' Call Book may link to that Slave.

**Slave Security** may be disabled (setting of **1**) allowing any Master to call the Slave.

**Slave Security** must be set to **1** when the unit is operating in Mode 6, Slave/Master Switchable or a Point-to-Point network where the Slave may need to accept calls from more than 10 different Masters. When **Slave Security** is set to **1**, the transceiver accepts calls from any other FreeWave transceiver. Additional network security measures may be taken to prevent unauthorized access, such as changing default settings for **Frequency Key**, **Hop Table**, or **Frequency Zones**.

## Transmit Power

Default Setting: 10

Options: Any number between 0 and 10

Setup Terminal Menu: (3) Edit Transmission Characteristics > (5) RF Xmit Power

Description: Sets the output power of the transceiver in dBm. In FGR2 radios, a setting of **10** is approximately 1 W of output power.

**Note:** When testing transceivers at your facility and they are in close proximity to one another, set the **Transmit Power** to a low number. When you deploy transceivers to the field, raise the **Transmit Power** number accordingly.

**Important:** The following table is for reference only. All Transmit Power settings below 9 are approximate.

Setting	Power (in mW) for FGR2 radios
0	5
1	10
2	35
3	80
4	140
5	230
6	330
7	480
8	600
9	800
10	1000

## Transmit Rate

Default Setting: (1) Normal

Options: (0) Diagnostics  
(1) Normal

Setup Terminal Menu: (3) Edit Transmission Characteristics > (3) Xmit Rate

Description: FreeWave transceivers have two available **Transmit Rate** settings. The setting for normal operation of the transceiver is **1**. When set to **0**, the transceivers transmit back and forth continuously regardless if they have any actual data. **0** should be used only as a diagnostic tool and not for normal operation. The strength of the signal may be gauged by the Clear to Send (CTS) LED. A solid red CTS LED indicates a strong signal; a blinking CTS LED indicates a weaker signal.

**0** is useful to qualitatively gauge signal strength in Point-to-Point mode.

---

## Chapter 3: Configuring Point-to-MultiPoint Networks

---

When installing MultiPoint networks it is important to do some up front planning around the devices you are going to implement and the route your data is going to take back to the Master. A MultiPoint network can contain the following devices:

- Only one Master. All communications are from and to the Master.
- An unlimited number of Slaves (remote sites).
- An unlimited number of Repeaters between any Slave and the Master.
- Serial Repeaters can be Slaves and Repeaters at the same time.

This chapter builds on the settings described in the previous chapters and provides details about the following setup that applies specifically to a MultiPoint network:

- Point-to-MultiPoint network characteristics.
- Using the Network ID or the Call Book to establish which transceivers in the network can communicate with each other.
- Using subnet IDs to route communication through the network, back to the Master.
- Settings and recommendations for additional parameters that apply to a MultiPoint network.
- Conserving power in devices within the network.
- Running network diagnostics.

## Point-to-MultiPoint Network Characteristics

A Point-to-MultiPoint network has the following unique characteristics.

### Golden Settings

A Point-to-MultiPoint network requires that the golden settings, as described on page 24, are set the same on all transceivers in the network.

If several independent MultiPoint networks are to be located in close proximity the planning becomes more critical. In such cases, it becomes very important to include as much frequency and time diversity as possible through use of different **Min and Max Packet Size**. In some instances the use of the **MultiMaster Sync** option may be required. For more information, about the **MultiMaster Sync** setting, see application note #5412, *Synchronizing Collocated Masters*, or contact FreeWave Technical Support.

In almost all MultiPoint networks, the **Frequency Key** is the same for all transceivers. In other networks, where parallel Repeaters are introduced, the **Frequency Key** value needs to change.

### Master-to-Slave Communication

Master-to-Slave communication within a MultiPoint network has the following characteristics:

- Data packets sent from the Master include a 32-bit CRC.
- The Master repeats its data broadcast between 0 to 9 times, depending on the setting in the **Master Packet Repeat** setting. For more information, see "Master Packet Repeat" on page 48.
- Slaves and Repeaters do not send acknowledgements to the Master when they receive data. When any Slave in the network receives the data packet from the Master with the 32-bit CRC, that Slave ignores any additional repeats of the data, and passes the data to its RS232 port.
- Repeaters in the network send data to Slaves and other Repeaters.

### Slave-to-Master Communication

Slave-to-Master communication within a MultiPoint network has the following characteristics:

- Data packets sent from the Slave to the Master include a 32-bit CRC.
- When the Master successfully receives data, it sends an acknowledgement to the Slave and passes the data to its RS232 port.

## Point-to-MultiPoint Network Quick Start

The following is a quick start guide for setting up two transceivers in Point-to-MultiPoint mode. This mode allows for a Master to communicate with several Repeaters and Slaves simultaneously.

### Point-to-MultiPoint Network Quick Start (Tool Suite):

1. Connect the transceiver to the serial port of a computer either through a serial cable or via the diagnostics cable. Make sure to connect the radio to a power source.

Power supply ranges and recommendations vary depending on model. Verify the specifications for the model you are using prior to connecting power.

2. Open a Tool Suite session, select the **Configuration** application, and ensure the correct port is selected in the **Com Port** field in the upper left of the Configuration ribbon.
3. From the Networks section of the Configuration ribbon, select the network in which the radio resides or click **Add Network** to create a new network in Tool Suite.
4. Click **Read Radio** in the Configuration ribbon to read the radio's current settings.

- If you are using a diagnostics cable to connect to the radio, the radio automatically goes into Setup mode.
- If you are using a data cable to connect to the radio, you are prompted to press the radio's Setup button to put the radio in Setup mode.
- When in Setup mode, all three LEDs on the radio display solid green.

5. Select the Operation Mode tab.

In the **Modem Mode** field, select **2** to set the radio as a Point-to-MultiPoint Master or select **3** to set the radio as a Point-to-MultiPoint Slave.

**Note:** A network can have only one Master.

6. Select the Baud Rate tab.

Change the **Baud Rate**, **Data Parity**, and **Modbus RTU** to match the device that the radio is to be attached to.

7. Select the Transmission Characteristics tab.

Set the following parameters so they are identical on all radios in the network:

- **Frequency Key**
- **Max Packet Size**
- **Min Packet Size**
- **RF Data Rate**

If several independent MultiPoint networks are located in close proximity, it becomes very important to include as much frequency and time diversity as possible through use of different **Frequency Key**, **Min and Max Packet Size**, and **Hop Table** settings.

Changing these settings from the factory defaults may help to eliminate interference from other FreeWave networks.

8. Select the MultiPoint Parameters tab.

In the **Network ID** field, set the value to any value between **1** and **4095**, except **255**. FreeWave recommends setting the **Network ID** to the last three or four digits of the Master radio's serial number, as this is a number you can look up if necessary. This value must be the same in all radios in the network.

#### **Point-to-MultiPoint Network Quick Start (Terminal Interface):**

1. Connect the transceiver to the serial port of a computer either through a serial cable or via the diagnostics cable. Make sure to connect the radio to a power source.
1. For board level configuration, connect the transceiver to a TTL-to-RS232 converter then connect to the serial port of a computer either through the data pins or diagnostics pins. Make sure to connect the radio to a power source.

Power supply ranges and recommendations vary depending on model. Verify the specifications for the model you are using prior to connecting power.

2. Open a terminal emulator session and use the following settings when connecting the radio. You can also use Setup Terminal within Tool Suite if a terminal emulator is unavailable:
  - Connect to COMx (where 'x' is the number of the Com port being connected).
  - Set the following:
    - **Data Rate** - 19,200
    - **Data Bits** - 8
    - **Parity** - none
    - **Stop bits** – 1
    - **Flow control** – none
3. Press the **Setup** button on the transceiver. If using the diagnostics cable, press **Shift-U** (capital U).
  - The three LEDs on the radio should all turn green, indicating Setup mode.
  - The Main menu displays on the screen.
4. Press **0** to access the Operation Mode menu.
  - Press **2** to set the radio as a Point-to-MultiPoint Master or press **3** to set the radio as a Point-to-MultiPoint Slave.
  - Press **Esc** to return to the Main menu.















































**Note:** A network can have only one Master.
5. Press **1** in the Main menu.
  - Change the **Baud Rate**, **Data Parity**, and **Modbus RTU** to match the device that the radio is to be attached to.
  - Press **Esc** to return to the Main menu.
6. Press **3** in the Main menu.
  - Set the following parameters so they are the same on all radios in the network:
    - **FreqKey**
    - **Max Packet Size**
    - **Min Packet Size**
    - **RF Data Rate**

The Frequency Key options is located in the F submenu after you press **0** to access the Frequency Key menu in Main menu **3**.

Changing these values may help to eliminate interference from other FreeWave networks.

- Press **Esc** to return to the Main menu.
7. Press **5** in the Main menu.
    - Set the **Network ID** value to any value between **1** and **4095**, except **255**. FreeWave recommends setting the **Network ID** to the last three or 4 digits of the radio's serial number.
    - Ensure this value is the same on every radio in the network.
  8. Press **Esc** to exit the Setup menu and resume normal radio operation.

## Point-to-MultiPoint Operation LEDs

Condition	Master			Slave			Repeater		
	Carrier Detect (CD)	Transmit (Tx)	Clear to Send (CTS)	Carrier Detect (CD)	Transmit (Tx)	Clear to Send (CTS)	Carrier Detect (CD)	Transmit (Tx)	Clear to Send (CTS)
Powered, not linked	Solid red bright 	Solid red dim 	Off 	Solid red bright 	Off 	Blinking red 	Solid red bright 	Off 	Blinking red 
Repeater and Slave linked to Master, no data	Solid red bright 	Solid red dim 	Off 	Solid green 	Off 	Solid red bright 	Solid green 	Solid red dim 	Solid red bright 
Repeater and Slave linked to Master, Master sending data to Slave	Solid red bright 	Solid red dim 	Off 	Solid green 	Off 	Solid red bright 	Solid green 	Solid red dim 	Solid red bright 
Repeater and Slave linked to Master, Slave sending data to Master	Solid green  RCV data or Solid red bright 	Solid red dim 	Intermittent flash red 	Solid green 	Intermittent flash red 	Solid red bright 	Solid green 	Solid red bright 	Solid red bright 
Master with diagnostics program running	Solid red bright 	Solid red dim 	Intermittent flash red 	Solid green 	Intermittent flash red 	Solid red bright 	Solid green 	Solid red bright 	Solid red bright 

\* in an idle condition, the CTS LED is solid red  with a solid link, as the link weakens the CTS LED on the Repeater and Slave begins to blink 

## Overlapping MultiPoint Networks

Overlapping MultiPoint networks may be set up effectively with FreeWave transceivers when several key parameters are set correctly. Overlapping MultiPoint networks are defined as networks using different Masters, which share or overlap in a specific geographic area. It may also include co-located transceivers configured into different networks. For more information, see application note #5412, *Synchronizing Collocated Masters (Multi-Master Sync Mode)*.

Co-located MultiPoint networks require the following parameters be unique for each network:

- **Network ID**, unless using the Call Book
- **Frequency Key** (in conjunction with Repeater Frequency)
- **Max Packet Size**
- **Min Packet Size**

For more information about the installation of Point-to-MultiPoint networks, contact FreeWave Technical Support.

## Establishing Communication with Other Transceivers in a MultiPoint Network

For the transceivers in your network to communicate successfully, you need to tell the transceiver what other devices are available for them to communicate with. You can use the **Network ID** or the Call Book. FreeWave

recommends using the **Network ID** option instead of the Call Book in MultiPoint networks. Because the **Network ID** does not use serial numbers, MultiPoint Masters and Repeaters may be added or replaced without reprogramming all of the Slaves in the network.

### Using the Network ID in MultiPoint Networks

The **Network ID** parameter is located in the MultiPoint Parameters tab. A transceiver from the factory has a **Network ID** setting of **255**, which enables the Call Book. Assign each transceiver in a single network the same **Network ID**. A Slave links with the first Master or Repeater it hears that has a matching **Network ID**.

Keep the following in mind when setting the **Network ID**:

- The value can be any value between 0 and 4095, except 255.
- To help ensure your ID is unique to your network, avoid using numbers that coincide with nearby landmarks or highways.
- FreeWave recommends a **Network ID** of four characters. For example, the last four digits of the Master's serial number, which is ensured to be unique and does not overlap with other nearby FreeWave networks.
- Use the **Network ID** function in conjunction with the **Subnet ID** feature (if necessary) to route data through the transceiver network.

### Using the Call Book in MultiPoint Networks

Although not recommended, the Call Book is an option in MultiPoint networks. If the **Network ID** feature is used in a MultiPoint network, no entries are needed in the Call Book of any of the transceivers.

---

**Important:** FreeWave recommends using the **Network ID** feature in a MultiPoint network. Using the Call Book in a MultiPoint network can cause delay in resuming communication if a Master is damaged.

---

For information about setting the Call Book, see "Using the Call Book in Point-to-Point Networks" on page 58.

In a MultiPoint network, the Slaves and Repeaters are not listed in the Master's Call Book. A Slave must have the Master and any Repeater it is going to use in *its* Call Book.

The following examples show the Call Books of a MultiPoint network comprised of a Master, Repeater, and Slave in which the Slave can communicate either through the Repeater or directly to the Master:

***MultiPoint Master Call Book (Unit Serial Number 900-0001)***

Entry	Number	Repeater 1	Repeater 2
(0)	000-0000		
(1)	000-0000		

No serial number entries are necessary in the Master's Call Book.

***MultiPoint Repeater Call Book (Unit Serial Number 900-0002)***

Entry	Number	Repeater 1	Repeater 2
(0)	900-0001		
(1)	000-0000		

***MultiPoint Slave Call Book (Unit Serial Number 900-0003)***

Entry	Number	Repeater 1	Repeater 2
(0)	900-0001		
(1)	900-0002		
(2)	000-0000		

At times, you may want to force a Slave to go through a specific MultiPoint Repeater. In this scenario, the Slave's Call Book should contain only the serial number for that Repeater as the entry on line 0.

## Programming Point-to-MultiPoint Extended Call Book

In a MultiPoint network, a Slave can be programmed to roam between Masters and Repeaters using the MultiPoint Extended Call Book function. A Slave with its Call Book configured as below communicates with any transceiver whose serial number appears in any of the three columns. Do the following to enable this functionality:

1. Set the **Network ID** to **255**.
2. In the Call Book, enter **999-9999** as the last entry in the first and second columns.
3. In the Call Book, set **Entry to Call** to **All**.

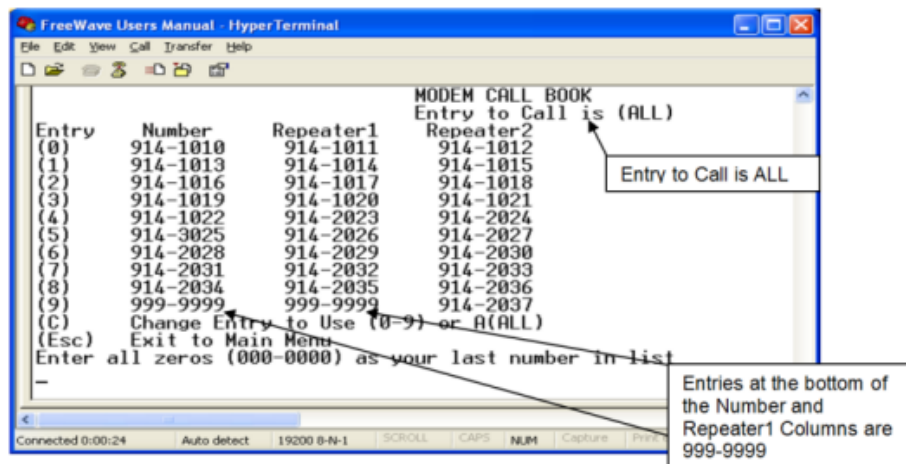

## Routing Communication Through the Network

When using the **Network ID** feature, a Repeater or Slave links to the first Repeater or Master it hears with the same ID. Using subnet IDs, you can determine the path a Repeater or Slave uses to communicate back to the Master. Subnet IDs are particularly helpful to force two Repeaters in the same network to operate in series rather than in parallel, or if desired, to force Slaves to communicate to a specific Repeater for load balancing purposes.

By forcing the communication path, you can optimize performance of the network by ensuring the Repeater or Slave links to a Repeater or Master with robust RF communications. Subnet IDs can help to minimize latency. By designing paths in a network, you can create the most efficient communication paths.

### Assigning Subnet ID Values

Subnet IDs consist of two parts, both available in the MultiPoint Parameters tab:

- **Rx** - This setting identifies which transceiver a Repeater or Slave listens to. In the terminal interface, this is the **Rcv Subnet ID**.
- **Tx** - This setting identifies the ID on which this device transmits, and in turn which devices listen to it. The **Tx Subnet ID** parameter is relevant for MultiPoint Masters and Repeaters **only**. In the terminal interface, this is the **Xmt Subnet ID**.

The default (disable) setting for both **Rx** and **Tx** is **F**, which is a visual way to indicate that the device is the final in the line of communication and does not use a subnet ID. A MultiPoint Slave with a **Subnet ID** of **F,F** does not roam from one Repeater or network to the next, it only links to a Master or Repeater that has either a **Tx** setting of **0** or an **F,F Subnet ID**.

Setting both **Rx** and **Tx Subnet ID** to **0** allows a mobile Slave to roam from subnet to subnet, and possibly from network to network, provided the **Network ID**, **Max and Min Packet Size**, and **RF Data Rates** are the same between networks.

The following illustration depicts a network in which subnet IDs are used to force communication. The subnet settings follow.

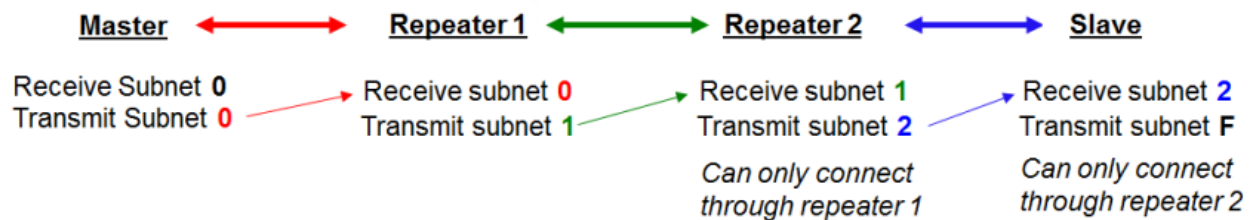

#### Subnet ID Settings for This Example

Transceiver	Rx	Tx	Additional Information
Master	0	0	The default settings (F, F) actually use 0, 0. The <b>Rx Subnet</b> on the Master has no effect on the network.
Repeater1	0	1	A <b>0</b> forces the transceiver to link only to the Master.
Repeater2	1	2	<b>Rx Subnet = 1</b> forces communication through Repeater 1. Repeater 1 transmits on subnet <b>2</b> .
Slave	2	F	<b>Rx SubnetID = 2</b> forces communication through Repeater 2. The Slave is the end of the network, so its <b>Tx Subnet</b> is <b>F</b> .

In the following example, Repeater 2 must communicate through Repeater 1, the Slave connected to Repeater 1 must route through Repeater 1. The other two Slaves must route through Slave/Repeater 2.

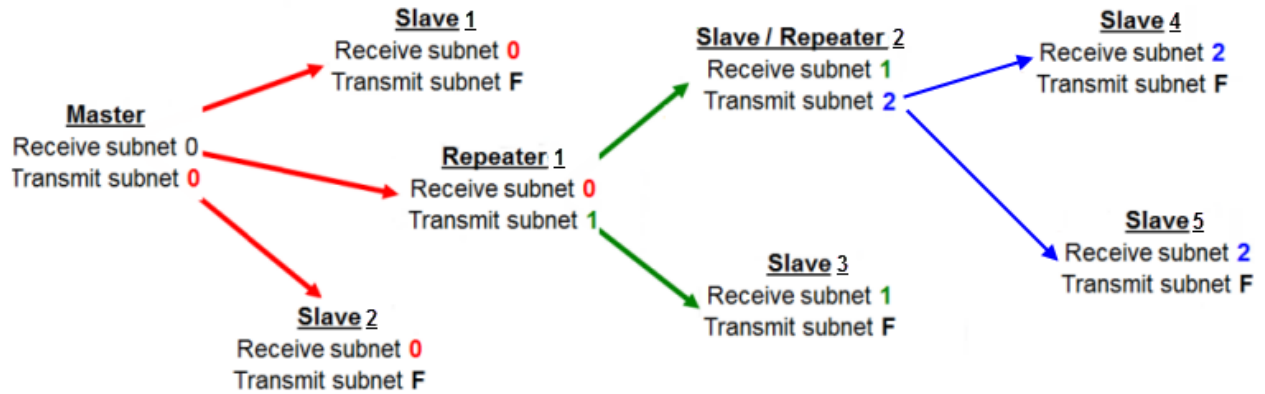

**Subnet ID Settings for This Example**

Transceiver	Rx	Tx	Additional Information
Master	0	0	The default settings (F, F) actually use 0, 0. The <b>Rx Subnet</b> on the Master has no effect on the network.
Slave 1	0	F	<b>Rx Subnet = 0</b> forces the transceiver to link only to the Master. The Slave does not transmit to any device except the Master, so its <b>Tx Subnet</b> is F.
Repeater1	0	1	<b>Rx Subnet = 0</b> forces the transceiver to link only to the Master. Transmits on subnet 1.
Slave 2	0	F	<b>Rx Subnet = 0</b> forces the transceiver to link only to the Master.
Slave/Repeater 2	1	2	<b>Rx Subnet = 1</b> forces the transceiver to link only to Repeater 1. It transmits on <b>Tx Subnet 2</b> to Slave 4 and 5.
Slave 3	1	F	<b>Rx Subnet = 1</b> forces the transceiver to link only to Repeater 1. The Slave does not transmit to any device except Repeater 1, so its <b>Tx Subnet</b> is F.
Slave 4	2	F	<b>Rx Subnet = 2</b> forces the transceiver to link with Slave/Repeater 2.
Slave 5	2	F	<b>Rx Subnet = 2</b> forces the transceiver to link with Slave/Repeater 2.

In the following example, Repeater 1 must talk directly to the Master; Repeater 2 must talk directly to Repeater 1. Slaves 1, 2, and 3 are forced along the direction of the solid lines. Slave 4 may link to the first Master or Repeater it hears in the network.

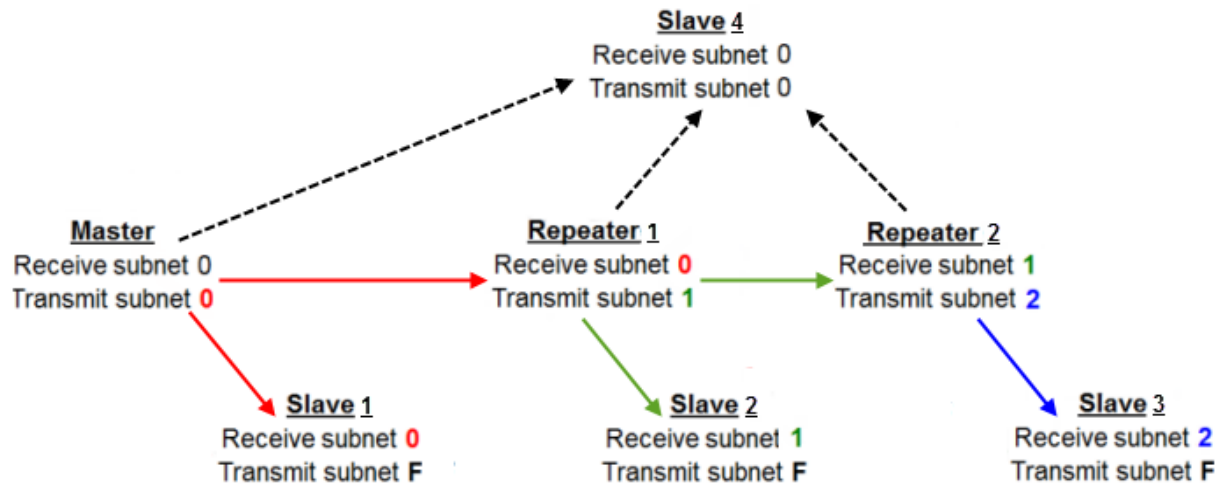

**Subnet ID Settings for this Example**

Transceiver	Rx	Tx	Other Information
Master	0-F	0-F	The default settings (F, F) actually use 0, 0. The <b>Rx Subnet</b> on the Master has no effect on the network.
Repeater1	0	1	A <b>0</b> forces the transceiver to link only to the Master.
Repeater2	1	2	<b>Rx Subnet</b> = 1 forces communication through Repeater1. Repeater1 transmits on SubnetID 1.
Slave 1	0	0 or F	<b>Rx Subnet</b> = 0 forces communication through Master.
Slave 2	1	0 or F	<b>Rx Subnet</b> = 1 forces communication through Repeater1.
Slave 3	2	0 or F	<b>Rx SubnetID</b> = 2 forces communication through Repeater2.
Slave 4	0	0	The <b>0,0</b> setting allows the Slave to link with the first Master or Repeater it hears with the same <b>Network ID</b> .

**Setting Other MultiPoint Parameters**

The other MultiPoint Parameters options allow you to modify several different parameters in the transceiver that determine the characteristics of a MultiPoint network.

Set the following parameters in the MultiPoint Parameters tab. These settings are available in the MultiPoint Parameters menu in the terminal interface.

**1 PPS Enable Delay**

Default Setting: 255

Options: 255 to disable 1 PPS  
0 to 254 to enter the delay

Setup Terminal Menu: (5) Edit MultiPoint Parameters > (9) 1 PPS Enable/Delay

**Description:** The **1 PPS Enable/Delay** setting allows the a 1PPS signal to propagate from the Master to all Slaves in a MultiPoint network. When this parameter is enabled a properly generated pulse applied on the DTR line of the Master provides a 1 PPS pulse on the CD line of any Slave in the network.

Follow the steps below to use the **1 PPS Enable/Delay** feature.

#### To setup 1PPS Enable/Delay:

1. Set the **1 PPS Enable/Delay** parameter to **0** in the Master.  
The Master must have a 1 PPS pulse on the DTR pin.
2. Enable the **1 PPS Enable/Delay** parameter on the Slaves. Slaves are calibrated at the factory.

#### To calibrate a Slave in 1PPS Enable/Delay mode:

1. Trigger an oscilloscope on the 1 PPS pulse on the DTR line of the Master.
2. Monitor the CD line of the Slave.
3. If the timing on the Slave differs from the Master it may be adjusted via the value in the Slave's **1 PPS Enable/Delay** parameter. The difference in time between each incremental integer value is 542.534 nS. Changing the parameter to higher values decreases the Slave time delay and changing the parameter to lower values increases the time delay.

When properly calibrated, the CD line Slave transceiver outputs a pulse that goes high for about 2 ms in synch with the 1 PPS pulse on the Master. The output on the Slave occurs within 20 microseconds of the input to the Master.

---

**Important:** When **1 PPS** is enabled, the Master must have a 1 PPS pulse on its DTR pin, otherwise the RF network does not function.

---

## Diagnostics

**Default Setting:** 0 (Disabled)

**Options:** Any number between 0 and 128

**Setup Terminal Menu:** (5) Edit MultiPoint Parameters > (B) Diagnostics

**Description:** Allows diagnostics data in the Network Diagnostics application within Tool Suite to be viewed at the Master in parallel with application data. The setting in this parameter determines how many slots out of 128 are dedicated to diagnostics. For example, if set to **10**, 1 out of every 10 data slots is for diagnostics data; if set to **100**, 1 out of every 100 data slots is for diagnostics data.

Diagnostics is always secondary to actual transmitted data.

For more information, see "Reading Diagnostics in Tool Suite" on page 54.

## DTR Connect

- Default Setting: (0) Off
- Options:
- **(0) Off** - When set to off in the Slave, the transceiver transmits when the data is received.
  - **(1) DTR Sensing** - Forms a Point-to-Point link with the Master when the DTR line is high to send data.
  - **(2) Burst Mode** - The transceiver transmits data in bursts.
- Setup Terminal Menu: (5) MultiPoint parameters > (4) DTR Connect
- Description: Determines how the transceiver sends its data. This mode is valuable when a network has many low data rate devices and you want to increase overall network capacity.
- If **DTR Connect** is set to **1** and the **RTS to CTS** function is enabled on the radio, then **RTS to CTS** takes precedence over **DTR Connect**.
- If **DTR Connect** is set to **2** and **RTS to CTS** is enabled, then **RTS to CTS** is ignored. The transceiver has two separate transmit and receive user data buffers. These buffers are 2 Kbytes each. In case of a buffer overflow, the transceiver outputs unpredictable data.

## Local Mode

- Default Setting: (0) Disabled
- Options: (0) Disabled, (1) Enabled
- Setup Terminal Menu: (5) Edit MultiPoint Parameters > (E) Local Access
- Description: Enable **Local Mode** to access a Slave with a local Master. This Master is not the network Master. For more information, see application note #5457, *Local Mode*.

## Master Packet Repeat

**Note:** When using the transceiver in **Modbus RTU** mode, the **Master Packet Repeat** setting must match in every transceiver, regardless of whether the network is in Point-to-Point or MultiPoint mode.

- Default Setting: 3
- Options: Any number between 0 and 9.
- Setup Terminal Menu: (5) Edit MultiPoint Parameters > (1) Master Packet Repeat
- Description: In a Point-to-MultiPoint network, Slaves do not acknowledge transmissions from the Master. If Slaves did acknowledge all data transmissions, in a large network, the Master would soon become overwhelmed with acknowledgments from the Slaves. Without acknowledgements, 100%

confidence every Slave has received every packet cannot be met.

To address this issue, you can modify the **Master Packet Repeat** parameter, assigning a value between **0** (the packet is transmitted once) to **9** (the packet is transmitted 10 times).

For networks with solid RF links, this parameter should be set to a low value such as **1** or **2**. If a network has some weak or marginal links it should be set with higher values. If a Slave receives a good packet from a Master more than once it discards the repeated packets. Similarly, after a MultiPoint Repeater receives a good packet from the Master, it discards any further repeated packets. In turn, the Repeater sends the packet out to the next Repeater or Slaves the number of times corresponding to its own **Master Packet Repeat** setting.

Increasing the **Master Packet Repeat** setting increases the probability of a packet getting through, but also increases latency in the network because each packet from the Master or Repeater is being sent multiple times. Therefore, it is important to find the optimal mix between network robustness, throughput, and latency. In general, a setting of **2** to **3** works well for most well designed networks.

**Note:** The **Master Packet Repeat** may be set to **0** if the user software is capable of, or requires acknowledgment. In this case, if the Master sends a packet that the Slave does not receive, the user software controls the retries as needed.

### Master Packet Repeat in MultiPoint Networks with Repeaters

The **Master Packet Repeat** parameter must also be set in MultiPoint Repeaters because a Repeater appears as a Master to a Slave. Therefore, the Repeater sends the packet out the number of times corresponding to its own **Master Packet Repeat** parameter. If this parameter is set improperly the reliability of the overall network may be diminished.

For example, if a Master's **Master Packet Repeat** setting is **3**, the link between the Master and Repeater should be robust. If the Repeater's **Master Packet Repeat** is set to **0**, this could cause marginal communications between the Repeater and the Slaves. The Slaves communicating through this Repeater only receive the initial packet from the Master with no repeats. Therefore, if the packet is not received on the first try, the Slave does not respond as expected.

**Note:** The **Master Packet Repeat** setting in any MultiPoint Repeater must be *less than or equal* to the Master's setting.

### Max Slave Retry

Default Setting:	9
Options:	Any number between 0 and 9.
Setup Terminal Menu:	(5) Edit MultiPoint Parameters > (2) Max Slave Retry
Description:	Defines how many times the Slave attempts to retransmit a packet to the Master before beginning to use a back-off algorithm (defined by the <b>Retry Odds</b> parameter). Slave retries stop when the Slave receives an

acknowledgement from the Master.

## Radio ID

Default Setting:	Blank
Options:	Any 4 digit, user-defined number.
Setup Terminal Menu:	(5) Edit MultiPoint Parameters > (D) Radio ID
Description:	Use this option to designate a transceiver with an arbitrary, user-defined, 4-digit number that identifies the transceiver in Diagnostics mode.

## Radio Name

Default Setting:	Blank
Options:	Any combination of letters or numbers up to 20 characters
Setup Terminal Menu:	(5) Edit MultiPoint Parameters > (G) Radio Name
Description:	Use this parameter to give a transceiver a name, such as its location. Naming transceivers can be helpful to identify a transceiver when in Diagnostics mode.

## Repeater Frequency

Default Setting:	(0) Disabled
Options:	(0) Disabled (1) Enabled
Setup Terminal Menu:	(5) Edit MultiPoint Parameters > (5) Repeater Frequency
Description:	Enable this parameter when you need a <b>Frequency Key</b> other than that of the Master. This condition occurs when parallel Repeaters in a network may have overlapping areas of responsibility. The default setting of <b>0</b> (Disabled) causes the Repeater to use the key set in the <b>Frequency Key</b> field in the Transmission Characteristics tab.  <b>Note:</b> When <b>Repeater Frequency</b> is disabled and <b>Subnets</b> are not configured, the <b>Frequency Key</b> setting in each Slave must match the Master or Repeater acting as the Master for the transceiver.

## Repeaters

**Note:** This parameter needs to be set in the MultiPoint Master only. The setting has no effect if set on a MultiPoint Slave.

Default Setting:	(1) Enabled
------------------	-------------

Options:	(0) Disabled (1) Enabled
Setup Terminal Menu:	(5) Edit MultiPoint Parameters > (0) Number Repeaters
Description:	Indicates if any number of Repeaters exist in the network.

## Retry Odds

Default Setting:	0
Options:	Any number between 0 and 9.
Setup Terminal Menu:	(5) Edit MultiPoint Parameters > (3) Retry Odds
Description:	<p>While packets transmitted from the Master to the Slaves in a MultiPoint network are not acknowledged, packets transmitted from Slaves to the Master are acknowledged. It is possible that more than one Slave attempts to transmit to the Master at the same time. Therefore, it is important that a protocol exists to resolve contention for the Master between Slaves. This is addressed through the <b>Max Slave Retry</b> and <b>Retry Odds</b> parameters. After the Slave has unsuccessfully attempted to transmit the packet the number of times specified in the <b>Max Slave Retry</b> parameter, it attempts to transmit to the Master on a random basis. The <b>Retry Odds</b> parameter determines the probability that the Slave attempts to retransmit the packet to the Master; a low setting assigns low odds to the Slave attempting to transmit. Conversely, a high setting assigns higher odds.</p> <p>An example of how this parameter might be used would be when considering two different Slaves in a MultiPoint network, one with a strong RF link and the other with a weak RF link to the Master. If a Slave has a weak or poor link, set <b>Retry Odds</b> to <b>0</b> as it may become a "chatty" Slave and lockup your network, causing a loss of communication.</p> <p>When <b>Retry Odds</b> is set to <b>0</b>, after the Slave has exhausted the number of retries set in the <b>Max Slave Retry</b> parameter and still not gained the Master's attention, the Slave's data buffer is purged. A <b>Retry Odds</b> set to <b>0</b> is recommended for most networks.</p>

## Slave/Repeater

Default Setting:	(0) Disabled
Options:	(0) Disabled (1) Enabled
Setup Terminal Menu:	(5) MultiPoint Parameters > (A) Slave/Repeater
Description:	The <b>Slave/Repeater</b> mode allows a transceiver in a MultiPoint network to switch between Slave and Repeater functions. When in this mode, a transceiver repeats any packets sent across the network as well as uses the data port. Thus, where one Repeater and one Slave may be required in

another vendor's network, FreeWave networks require only one transceiver. To operate a transceiver as a MultiPoint Slave/Repeater, the following must be set:

- The **Modem Mode** parameter in the Operation Mode tab must be set to **MultiPoint Repeater**.
- The **Slave/Repeater** parameter in the MultiPoint Parameters tab must be enabled.

## Conserving Power

Power consumption can be essential, especially for remote sites that are difficult to access.

You can conserve power using the following options available in the Transmission Characteristics tab. These settings are available in the Radio Transmission Characteristics menu in the terminal interface.

- **Low Power Mode** - Available in MultiPoint Slaves using RS232. Conserves power primarily by dimming the transceiver's LEDs. For more information, see "Low Power Mode" on page 52.
- **Remote LEDs** - If the transceiver has the optional 20-in connector, you can use this option to connect remote LEDs through the diagnostics port. This feature may be used to save power in MultiPoint Repeaters where the other options are not available. For more information, see "Remote LED" on page 32.

### Low Power Mode

**Note:** This setting applies only to MultiPoint Slaves using a RS232 protocol (available in the MM2-MR-R models). **Low Power Mode** does not work with MultiPoint Repeaters because they are constantly transmitting.

Default Setting: 0

Options: Any number between 0 and 31. The higher the number, the greater the power consumption decrease.

Setup Terminal Menu: (3) Edit Radio Transmission Characteristics > (9) Low Power Mode

Description: Allows a MultiPoint Slave to consume less power, primarily by dimming the transceiver's LEDs.

When set to **2** through **31**, the transceiver sleeps between slots. For example, at a setting of **2** the transceiver sleeps 1 out of 2 slots; at a setting of **3** the transceiver sleeps 2 out of 3 slots, and so on.

When the transceiver is asleep, it hears nothing from the Master.

The following table shows the changes at different **Low Power Mode** settings. The actual current draw depends on many factors. The table below gives only a qualitative indication of supply current savings. A low number reduces latency and a high number reduces current consumption.



Setting	Description
0	Low power, disabled.
1	LEDs dimmed, transceiver remains awake, transceiver is listening to the Master's transmissions on every slot, and transceiver's data port is shut down if the RTS line is de-asserted (low). In this case, the transceiver needs to be awakened before it is able to send data to the Master.
2	LEDs dimmed, transceiver sleeps every other slot.
3	LEDs dimmed, transceiver sleeps 2 of 3 slots.
4-31	LEDs dimmed, transceiver sleeps the number of slots corresponding to the setting. For example, with a setting of 31 the transceiver sleeps 30 of 31 slots.

Note the following about the **Low Power Mode** parameter:

- Power savings occur only when the Slave is linked. No power savings occur when the Slave is transmitting data. **Low Power Mode** is of little value when a Slave has a constant, high throughput. **MCU Speed** must be set to **0** and **RF Data Rate** must be set to **3** for **Low Power Mode** to operate properly.
- To communicate to an RS232 port of a transceiver that is in **Low Power Mode**, the RTS line must be held high to wake it up. The transceiver wakes up within approximately 20 milliseconds of when RTS goes high.
- If the Request to Send (RTS) line on the Slave is held high, the transceiver remains in normal operation regardless of the **Low Power Mode** setting. After RTS is dropped the transceiver reverts to the **Low Power Mode**.
- If the transceiver has the **DTR Connect** option In the MultiPoint Parameters tab set to **1** or **2** and if the **Low Power Mode** is enabled (set to **1-31**), the RTS line on the transceiver must be asserted for the **DTR Connect** feature to operate properly.
- The diagnostic pins must be disabled or terminated to a cable for the Sleep current in Lower Power Mode to match the specifications. To disable the diagnostic pins, ensure the following are set:
  - In the Baud Rate tab, the **Setup Port** parameter is set to **1 (Main Only)**.
  - In the MultiPoint Parameters tab, the **Diagnostics** parameter is set to **0 (Off)**.
- To realize full power savings in **Low Power Mode**, the serial port must be deactivated between operation. To do that the RTS line must be asserted. However, because RS485/422 operation uses the RTS line as part of the data bus, it cannot be asserted to wake-up the radio. Therefore, FreeWave recommends that all radios set to RS485 or RS422, use a **Low Power Mode** of **0**.

## Reading Diagnostics in Tool Suite

The Network Diagnostics application provides a place to view diagnostic data for all the devices connected to the Master in your network in real time. This application is **not** meant to replicate the functionality of an NMS system, but rather it is a tool that can be used for diagnostics and troubleshooting in the field.

---

**Important:** The Network Diagnostics application is intended for occasional network monitoring or troubleshooting, not for continuous, long-term collection of diagnostic data.

---

This section provides basic steps for reading diagnostics using Tool Suite. Tool Suite stores the diagnostic data in the database and you can import or export a diagnostic file. For information regarding the data available, recommended best practices, and importing and exporting files using the Network Diagnostics application, see the *Tool Suite User Manual* available on the *User Manual and System Tools* CD or by selecting **File > Help** in the Tool Suite software.

**Note:** To help identify the transceivers in your network when running Network Diagnostics, set the **Radio Name** and **Radio ID** fields in the MultiPoint Parameters tab.

The diagnostic program **must** be run from the Master transceiver. Diagnostics requires the following:

- A setting of this parameter on the Master between 1 and 128.
- A second computer or serial connection to run the diagnostics software.
- A diagnostics cable. (Available from FreeWave.)
- Diagnostics software. (Available on the *User Manual and System Tools* CD and on [www.freewave.com](http://www.freewave.com).)

For more information about Diagnostics, contact FreeWave Technical Support.

### To run diagnostics using Tool Suite:

1. Connect the Master to the computer running Tool Suite.
2. Open Tool Suite and click **Network Diagnostics** in the Applications pane.
3. From the drop-down menu in the Networks section of the ribbon, select the serial network for which you want to run diagnostics.

If you do not have a network defined, click **Add** and follow the instructions in the wizard. For more information, see the *Tool Suite User's Manual*.

4. From the ribbon, click **Start**.
5. To stop running diagnostics, click **Stop**.

If you move away from the Network Diagnostics application without selecting **Stop**, the program continues to poll for diagnostic data.

---

**Important:** Tool Suite is not optimized for the collection and management of large amounts of diagnostic data from continuous polling. Collection of excessive amounts of data results in overall performance degradation in Tool Suite and network throughput degradation.

---

---

## Chapter 4: Configuring Point-to-Point Networks

---

Point-to-Point networks are the most basic type of network, and do not require much more than setting up the basic network, as described in the basic programming and setup chapter.

This chapter provides:

- A brief quick start to setup a Point-to-Point network.
- An LED chart for LED function within a Point-to-Point network.
- Information about programming the Call Book.

### Point-to-Point Network Quick Start

To establish communications between a pair of FreeWave transceivers just received from the factory, complete the steps described below for each transceiver.

#### Point-to-Point Network Quick Start (Tool Suite):

1. Connect the transceiver to the serial port of a computer either through a serial cable or via the diagnostics cable. Make sure to connect the radio to a power source.

For board level configuration, connect the transceiver to a TTL-to-RS232 converter then connect to the serial port of a computer either through the data pins or diagnostics pins. Make sure to connect the radio to a power source.

Power supply ranges and recommendations vary depending on model. Verify the specifications for the model you are using prior to connecting power.

2. Open a Tool Suite session, select the **Configuration** application, and ensure the correct port is selected in the **Com Port** field in the Configuration ribbon.
3. From the Networks section of the Configuration ribbon, select the network in which the radio resides or click **Add Network** to create a new network in Tool Suite.
4. Click **Read Radio** in the Configuration ribbon to read the radio's current settings.

- If you are using a diagnostics cable to connect to the radio, the radio automatically goes into Setup mode.
  - If you are using a data cable to connect to the radio, you are prompted to press the radio's Setup button to put the radio in Setup mode.
  - When in Setup mode, all three LEDs on the radio display solid green.
5. Select the Operation Mode tab.

In the **Modem Mode** field, select to set the radio in Point-to-Point mode. For example, set one radio as a Point-to-Point Master (Mode 0) and the other as a Point-to-Point Slave (Mode 1). For more information about modem modes, see "Setting the Transceiver's Role in the Network and the Network Type" on page 17.

**Note:** A network can have only one Master.

6. Select the Baud Rate tab.

Change the **Baud Rate**, **Data Parity**, and **Modbus RTU** to match the device that the radio is to be attached to.

7. Select the Transmission Characteristics tab.

Set the following parameters so they are identical on all radios in the network:

- **Frequency Key**
- **Max Packet Size**
- **Min Packet Size**
- **RF Data Rate**

If several independent MultiPoint networks are located in close proximity, it becomes very important to include as much frequency and time diversity as possible through use of different **Frequency Key**, **Min and Max Packet Size**, and **Hop Table** settings.

Changing these settings from the factory defaults may help to eliminate interference from other FreeWave networks.

8. Select the Call Book tab.

Enter the Slave serial number in the Master's Call Book. Enter the Master's Serial number in the Slave's Call Book, or disable Slave Security (in the Slave). For more information about setting up the Call Book see "Using the Call Book in Point-to-Point Networks" on page 58.

Shortly after both transceivers are plugged in, they should establish a communications link with each other and the connection is complete. Using the table below, verify that the radios are operating as expected.

#### **Point-to-Point Network Quick Start (Terminal Interface):**

1. Connect antennas to the transceivers.
2. Connect the transceiver to the serial port of a computer either through a serial cable or via the diagnostics cable. Make sure to connect the radio to a power source.

Power supply ranges and recommendations vary depending on model. Verify the specifications for the model you are using prior to connecting power.

3. Open a terminal emulator session and use the following settings in connecting the radio. You can also use Setup Terminal within Tool Suite if a terminal emulator is unavailable.
  - Connect to COMx (where 'x' is the number of the port being connected).
  - Set the following:
    - **Data Rate** - 19,200
    - **Data Bits** - 8
    - **Parity** - none
    - **Stop bits** - 1
    - **Flow control** - none
4. Press the **Setup** button on the radio. If using the diagnostics cable, press **Shift-U** (capital U).
  - The three LEDs on the radio should all turn green, indicating Setup mode.
  - The Main menu displays on the screen.
5. Press **0** to access the Operation Mode menu.
  - Press **0** to set the radio as a Point-to-Point Master or press **1** to set the radio as Point-to-Point slave. For more information about modem modes, see "Setting the Transceiver's Role in the Network and the Network Type" on page 17.
  - Press **Esc** to return to the Main menu.
6. Press **1** in the Main menu.
  - Change the **Baud Rate**, **Data Parity**, and **Modbus RTU** to match the device that the radio is to be attached to.
  - Press **Esc** to return to the Main menu.
7. Press **2** in the Main menu to update the Call Book.

Enter the Slave serial number in the Master's Call Book. Enter the Master's Serial number in the Slave's Call Book, or disable Slave Security (in the Slave). For more information about setting up the Call Book, see "Using the Call Book in Point-to-Point Networks" on page 58.
8. Press **3** in the Main menu.
  - Set the following parameters so they are the same on all radios in the network:
    - **FreqKey**
    - **Max Packet Size**
    - **Min Packet Size**
    - **RF Data Rate**

The Frequency Key options is located in the F submenu after you press **0** to access the Frequency Key menu in Main menu **3**.

























































Changing these values may help to eliminate interference from other FreeWave networks.

- Press **Esc** to return to the Main menu.

Shortly after both transceivers are plugged in, they should establish a communications link with each other and the connection is complete. Using the table below, verify that the radios are operating as expected.

9. Press **Esc** to exit the Setup menu and resume normal radio operation.

## Point-to-Point Operation LEDs

Condition	Master			Slave			Repeater		
	Carrier Detect (CD)	Transmit (Tx)	Clear to Send (CTS)	Carrier Detect (CD)	Transmit (Tx)	Clear to Send (CTS)	Carrier Detect (CD)	Transmit (Tx)	Clear to Send (CTS)
Powered, no link	Solid red bright 	Solid red bright 	Solid red bright 	Solid red bright 	Off 	Blinking red 	Solid red bright 	Off 	Blinking red 
Linked, no Repeater, sending sparse data	Solid green 	Intermittent flash red 	Intermittent flash red 	Solid green 	Intermittent flash red 	Intermittent flash red 	n/a	n/a	n/a
Master calling Slave through Repeater	Solid red bright 	Solid red dim 	Solid red bright 	Solid red bright 	Off 	Blinking red 	Solid red bright 	Off 	Blinking red 
Master linked to Repeater, not to Slave	Flashing orange 	Solid red dim 	Solid red bright 	Solid red bright 	Off 	Blinking red 	Solid Red bright 	Solid red dim 	Solid red bright 
Repeater linked to Slave	Solid green 	Intermittent flash red 	Intermittent flash red 	Solid green 	Intermittent flash red 	Intermittent flash red 	Solid green 	Intermittent flash red 	Intermittent flash red 
Mode 6 - waiting for ATD command	Solid red bright 	Off 	Blinking red 	Solid red bright 	Off 	Blinking red 	n/a	n/a	n/a
Setup Mode	Solid green 	Solid green 	Solid green 	Solid green 	Solid green 	Solid green 	Solid green 	Solid green 	Solid green 

## Using the Call Book in Point-to-Point Networks

The Call Book is required in Point-to-Point networks. While the Call Book is an option in Point-to-MultiPoint networks, FreeWave strongly recommends using the **Network ID** feature in most applications. If a large MultiPoint network is implemented using the Call Book and you want to add a transceiver to the network, or need to replace a transceiver, you must physically travel to all transceivers in the network and enter the new serial number in the transceiver's Call Book.

Using the Call Book offers both security and flexibility in determining how FreeWave transceivers communicate with each other.

You must set the following for two FreeWave transceivers to communicate in Point-to-Point mode:

1. The Master's serial number must be listed in the Slave's Call Book or Slave Security is turned off in the Slave .
2. The Slave's serial number must be listed in the Master's Call Book .
3. The Master must be programmed to call the Slave.

The Call Book allows you to incorporate up to 10 FreeWave transceivers, designate 1 to 4 Repeaters to use with each transceiver, and designate which Slave the Master calls. To set the **Entry to Call** option, select the number in the **Entry to Call** field, select **All** to direct the Master to call all Slaves.

**Note:** To set the **Entry to Call** option in the terminal interface, enter **C** at the Call Book menu, followed by the menu number corresponding to that Slave. To call any available Slave in the list, enter **C** then enter **A** to direct the Master to **Call All**.

It is important that the Call Book slots (0-9) are filled sequentially starting with slot 0. When a Master is instructed to **Call All**, it calls all Slaves listed until it reaches the first serial number of 000-0000 (or a blank slot). If a serial number is entered after the all zero number or as a Repeater, the Master does not recognize it as a valid number.

**Note:** When entering numbers into the Call Book, you need only define Repeaters in the Master's Call Book. The Slave Call Book only requires the Master's serial number. A Repeater need not have anything listed in its Call Book.

#### To set the call book in Tool Suite:

1. In the Tool Suite Configuration application, select the device to program and click the **(2) Call Book** tab.
2. In the **Number** column in **Row 0**, enter the seven-digit serial number of the transceiver being called.
3. In the **Repeater 1** column, enter Repeater 1's seven-digit number. If no Repeaters are being used, leave the column empty.
4. In the **Repeater 2** column, enter the second Repeater's seven-digit number. If only one Repeater is being used, leave the column empty.
5. If Repeaters are being used, select the appropriate **Entry to Call** option in the Master's Call Book.

To apply the changes, select either the Quick or All icon. Tool Suite applies the changes to the transceiver.

#### To set the Call Book in the terminal interface:

1. Select **(2) Call Book** from the main Setup menu to display the following window:

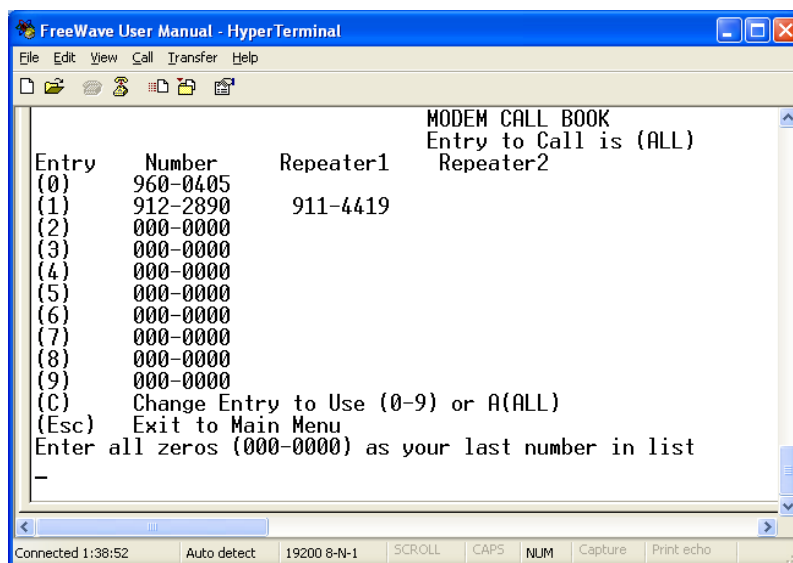

2. Enter the number or letter associated with the option you want to select.
3. Enter the seven-digit serial number of the transceiver being called.

4. The system prompts for Repeater 1's serial number. If no Repeaters are being used, press **Esc** and continue with step 6. Otherwise, enter the 7-digit serial number of the Repeater.
5. The system prompts for Repeater 2's serial number. Enter the 7-digit serial number of the second Repeater. If only one Repeater is being used, press **Esc**.

The system refreshes the transceiver's Call Book menu with the new changes.

6. Press **Esc** to return to the Main menu.

### Programming Point-To-Point Extended Call Book to Use Three or Four Repeaters

In a Point-to-Point configuration, FreeWave transceivers can use up to four Repeaters. To use three or four Repeaters, program the Call Book with the Slave's serial number, followed by the first two Repeaters. On the next line enter 999-9999 as the transceiver to call. When prompted for the Repeaters enter the third and fourth Repeaters in the link.

The illustration below shows a Point-to-Point link where a Slave is called through four Repeaters. In this example the Master is calling the Slave, 571-3872, through Repeater 1, 901-1234, then Repeater 2, 910-0234, then Repeater 3, 571-3456, and finally Repeater 4, 571-4567. Entering the serial number 999-9999 in line 1 instructs the Master to continue calling through the Repeaters programmed on that line.

Entry	Number	Repeater 1	Repeater 2
0	571-3872	901-1234	910-0234
1	999-9999	571-3456	571-4567
2			
3			
4			
5			
6			
7			
8			
9			

To call a Slave through one or more Repeaters, that Slave must be called individually. With **Call All** selected, the Master will not connect with any Slaves through Repeaters. The Master calls every Slave in the list and connects with the first Slave that responds. When calling through a Repeater, the Master must first call that Repeater and establish a communication link with it prior to making contact with the Slave.

---

## Chapter 5: Advanced Programming

---

The settings and scenarios covered in this chapter are considered advanced programming, and are settings and scenarios that you are not as likely to use in your network.

### Working with Parallel Repeaters

As you add Repeaters to your network, plan accordingly do avoid creating a parallel Repeater scenario. A parallel Repeater is defined as two or more Repeaters linked to the same point in the network.

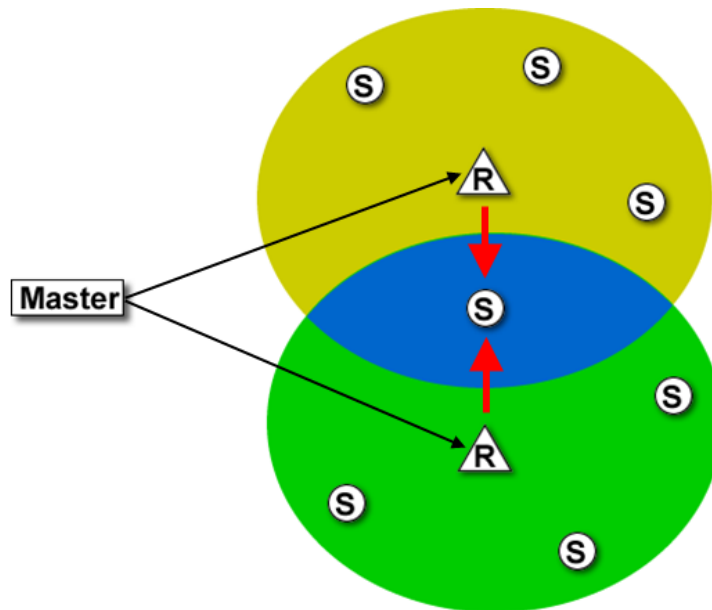

The Slave in the middle has overlapping coverage from both the Repeaters (parallel Repeaters). Data from the Repeaters is transmitted on the same **Frequency Key** in the same time slot, which creates message collisions.

To resolve this scenario, change the following settings on one or more of the Repeaters in conflict:

- **Repeater Frequency** - Set the **Repeater Frequency** parameter in the MultiPoint Parameters tab to any number other than **0**. If set to a number other than **0**, the transceiver uses the frequency key set in the **Frequency Key** parameter in the Transmission Characteristics tab, instead of the key assigned to the Master.
- **Frequency Key** - Set the **Frequency Key** parameter in the Transmission Characteristics tab to a key other than that of the conflicting Repeater.

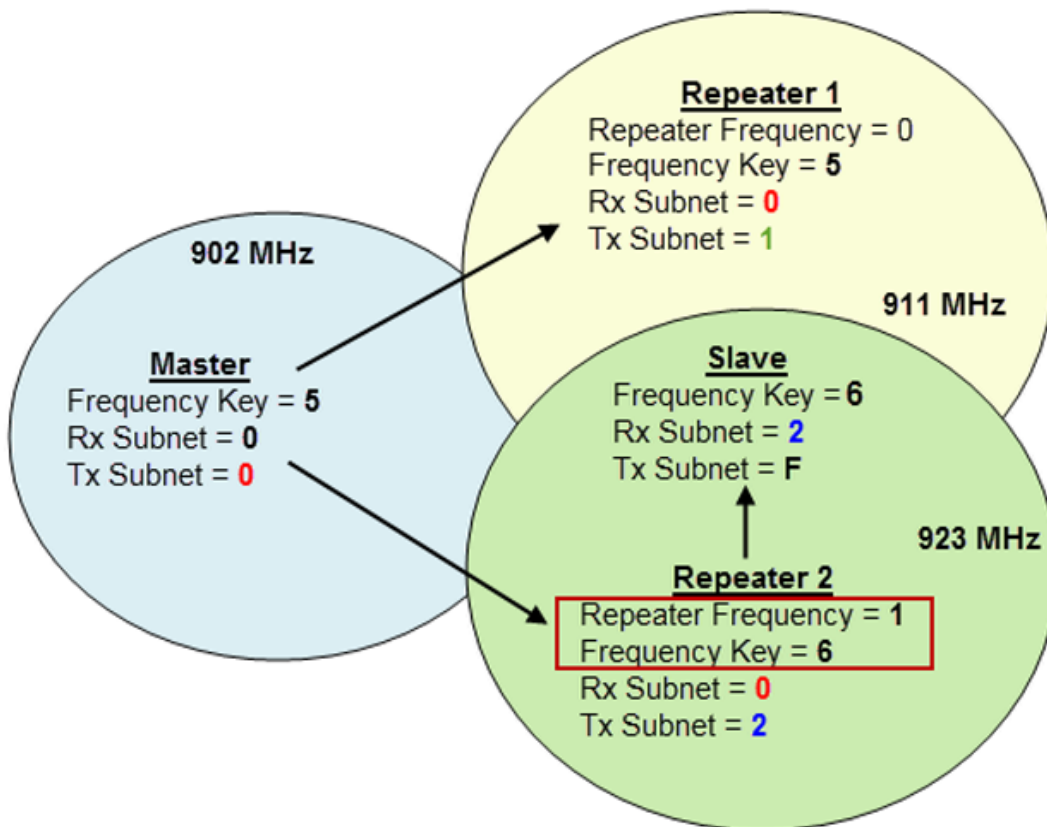

If you need to add a Repeater to your network, use the following steps to help ensure that you resolve any parallel Repeater issues up front, before deploying the Repeater in the network.

1. From within Tool Suite, run a network diagnostics file. You can also gather the settings from all the Repeaters that are currently in your network.
2. Review the network diagnostics file, paying special attention to the following settings on each Repeater and the Master
  - **Frequency Key**
  - **Repeater Frequency**
  - **Rx and Tx Subnet IDs**

- On a piece of paper, draw your network, noting the above settings for each Repeater, ensuring there are no duplicates.

If there are duplicates, change the Repeater Frequency and the Frequency Key parameters as described above.

If the Repeater you are adding is the only Repeater in the network, set the **Frequency Key** to match the Master, the **Rx Subnet ID** to match the Master's **Tx Subnet ID** setting, and the **Tx Subnet ID** to 1. In the Master, set the **Repeaters** parameter to **Enabled**.

## Setting Transceiver Passwords

Use passwords to prevent access to or changing of any of the transceiver's parameters. This option is useful if you want to prevent unauthorized personnel from gaining access to the transceiver settings.

If the **Setup Port** option in the Baud Rate tab is set to **(1) Main Only** or **(3) Both**, the password is only accepted if the option is accessed from the main data port. To use the Password function using the diagnostics port, the **Setup Port** option must be set to **(2) Diagnostics Only**.



**Warning!** If the password feature is enabled and the password is forgotten, you need to return the transceiver to FreeWave to have the password disabled.

### To set a password:

- From the Setup main menu in the terminal interface, select **(8) Chg Password** to display the following prompt:  
New PW? (<esc> to exit)
- To back out of the process and not enable the password press **Esc**. To set a password, type exactly four characters. Passwords are case sensitive.  
Press **Esc** to cancel the process at any point.
- After you enter the four characters the following prompt displays:  
<Enter> to accept, <esc> to quit.
- To accept the password as entered and enable the feature, press **Enter**. To quit the process and not enable the password, press **Esc**.  
If you press **Enter**, the password displays on the line above. The password is case sensitive and every keystroke is a character.

### To change a password:

After the password feature has been enabled, it is possible to change to a new password.

- From the Setup main menu in the terminal interface, select **(8) Chg Password**.
- At the Enter Security Code prompt enter the current four character, case sensitive password.  
After entering the password correctly, the prompt to enter the new password displays. Enter the new four character, case sensitive password.  
Press **Esc** to cancel this process at any point.
- To accept the password as entered and enable the feature, press **Enter**. To quit the process and not enable the password, press **Esc**.

If you press **Enter**, the password displays on the line above. The password is case sensitive and every keystroke is a character.

### To disable a password:

After the password features has been enabled, it is possible to disable the password if you know the current password.

---

**Important:** You can only disable a password using the prompt when you read the radio in Tool Suite, or through a terminal emulator. You cannot disable the password using Setup Terminal within Tool Suite.

---

1. From the Setup main menu in the terminal interface, select **(8) Chg Password**.
  2. Hold down the **Alt** key and type **0255** using the number pad on your keyboard and release the **Alt** key.
  3. Repeat this step three more times (hold **Alt** and type **0255** a total of 4 times).
- 

**Important:** You must type the **0255** using the NUM Pad on your computer, not the top row of numerals.

---

After the fourth entry, the password is disabled.

## About AES Encryption

Protecting the confidentiality, integrity, and authenticity of your data communication is essential to maintaining a robust, reliable, and secure wireless infrastructure. FreeWave has incorporated a number of mechanisms to achieve these critical security objectives, including the use of AES encryption. When available and enabled, AES Encryption adds a layer of 128-bit, 192-bit, or 256-bit encryption strength to the data before it is sent out via RF.

**Note:** AES encryption is available as an option set at the factory in firmware version v10.6.6 and later.. To upgrade an existing transceiver to use the AES functionality, contact FreeWave Technical Support or assistance.

To set AES encryption, you need to select the encryption strength and provide an encryption key. For more information, see the descriptions below.

### Encryption

**Note:** AES encryption settings are only available through the terminal interface. The encryption options are not available in the Tool Suite Transmission Characteristics tab. If your transceiver did not have **Encryption** enabled at the factory, this parameter displays in the menu list, but has no function.

---

**Important:** Every transceiver in the network must have matching encryption strengths and encryption keys for successful communication.

---

Default Setting: (0) Off

- Options:
- **(0) Off** - Turns off AES encryption.
  - **(2) AES128** - Enables AES encryption, 128-bit strength.

- **(3) AES192** - Enables AES encryption, 192-bit strength.
- **(4) AES256** - Enables AES encryption, 256-bit strength.

Setup Terminal Menu: (3) Edit Radio Transmission Characteristics > (E) Encryption

Description: AES encryption is available in various strengths. Your network, and the data you are sending determines the encryption strength you should use. The higher the encryption strength, the stronger the encryption; however, it can also take longer for the encryption and de-encryption to take place.

If you enable AES encryption, you need to also set the encryption key. For more information, see "Encryption Key" on page 65.

For more information about AES encryption, see "About AES Encryption" on page 64.

## Encryption Key

**Note:** AES encryption settings are only available through the terminal interface. The encryption options are not available in the Tool Suite Transmission Characteristics tab. If your transceiver did not have **Encryption** enabled at the factory, this parameter displays in the menu list, but has no function.

---

**Important:** Every transceiver in the network must have matching encryption strengths and encryption keys for successful communication.

---

Default Setting: Blank

Options: Any set of hexadecimal pairs as described below.

Setup Terminal Menu: (3) Edit Radio Transmission Characteristics > (E) Encryption > (5) Enter Key

Description: The encryption key is the piece of information used to encrypt and de-encrypt the data sent through your network. Even with encryption, your data is only as secure as the strength of the encryption key you use. Keys should be random in nature and entered as hexadecimal values (0-F in two-character pairs). You can use any combination of characters for your password. For example, a combination of numbers that you know, or a sentence or phrase converted into hexadecimal format. Various string-to-hexadecimal converters are available on the Internet.

Enter the encryption key in the 2-character hexadecimal combinations in the lines provided:

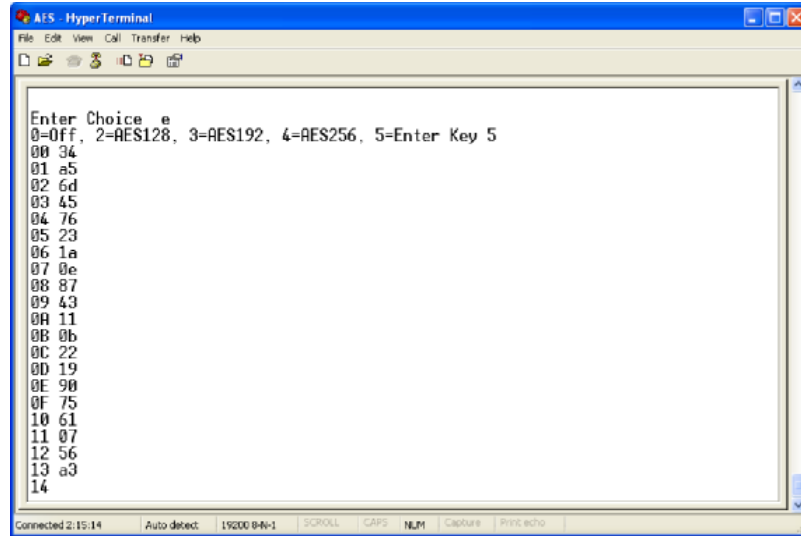

The **Enter Key** option always asks for all 32 lines of the encryption key. However, the encryption strength you select determines how many of the lines are required:

- **128-bit encryption** - Enter key information in rows 00 to 0F. The last 16 lines (10 to 1F) are ignored.
- **192-bit encryption** - Enter key information in rows 00 to 17. The last 8 entries (18 to 1F) are ignored.
- **256-bit encryption** - Enter key information in rows 00 to 1F. All lines are used.

## Low Baud Rates

The transceiver's baud rate may be set to 300, 600, or 900 baud. For more information about using a low baud rate, contact FreeWave technical support.

## Multi-Master Synch

The **Multi-Master Synch** setting is reserved for applications, in both Point-to-Point and MultiPoint modes, with concentrations of Master units where it is necessary to reduce interference between the Masters. For more information, see application note #5412, *Synchronizing Collocated Masters*, or contact FreeWave Technical Support.

## Time Divisible Multiple Access (TDMA)

Available in some transceiver models, the FreeWave Time Division Multiple Access (TDMA) protocol is an enhanced and sophisticated version of Point-to-MultiPoint communications. The TDMA protocol provides timing and other parameters, which in turn allow large transceiver networks to work in a non-pollled environment.

This option is only used for peer-to-peer communications or when applications are very time specific. For additional information about TDMA, contact FreeWave Technical Support.

---

## Chapter 6: Viewing Radio Statistics

---

When you read a radio the system displays data transmission statistics the transceiver has gathered during the most recent session. This information is valuable when you need to know the signal strength and noise levels of the link. Statistics are gathered during each data link and are reset when the next link begins.

In addition, you can view more data transmission characteristics in the Network Diagnostics application. For information about running network diagnostics using Tool Suite, see the *Tool Suite User Manual*.

### To display the radio statistics in Tool Suite:

1. In the Tool Suite Configuration application, click **Read Radio**, and then click the Device Information tab.
2. Review the radio characteristics. Each characteristic is described in detail in the sections below.  
You can also view the same statistics using the Setup Terminal option in Tool Suite.

### To display the Radio Transmission Characteristics in the terminal interface:

1. Select **(4) Show Radio Statistics** from the Setup main menu to display the following window:  
Review the radio characteristics. Each characteristic is described in detail in the sections below.

## Antenna Reflected Power

This statistic is not valid in the MM2 transceivers.

This is a measurement of the transmitted power that is reflected back into the transceiver from mismatched antennas or cables, or loose connections between the transceiver and antenna. A reading of 0 to 5 is good; 5 to 20 is marginal; 20 or higher indicates that the connections should be inspected for loose connections and cable quality. A reading of 30 or higher indicates a definite problem in the system.

The most likely reason for a higher **Antenna Reflected Power** reading is a cable issue between the radio and the antenna: loose connections, cable kinks, breaks in cable shielding, moisture in the fittings or connections,

etc. Less commonly, a high **Antenna Reflected Power** reading can indicate a hardware problem with the radio itself, such as a damaged RF connector. Lastly, a high reading may indicate a problem with the antenna itself, although antenna problems are the least likely indicator.

## Master-Slave Distance

The physical distance between the slave radio and the master radio in your network. This distance is most accurate at a distance greater than 2.5 miles.

## Noise Level

The **Noise Level** indicates the level of background noise and interference at this transceiver and at each of the Repeaters in the link. The number is an average of the noise levels measured at each frequency in the transceiver's frequency hop table.



The individual measurement values at each frequency hop channel are shown in the frequency table. If you are viewing statistics in the terminal interface, press **Enter** when the Radio Statistics menu displays to view the frequency table.

Ideally, the difference between the average signal level and average noise level should be 26 or more. Noise levels significantly higher than this are an indication of a high level of interference that may degrade the performance of the link. High noise levels can often be mitigated with band pass filters, antenna placement or antenna polarization.

## Number of Disconnects

Anytime the link between the Master and the Slave is broken and the radios lose Carrier Detect.

The value indicates the total number of disconnects that have occurred from the time the transceiver is powered on until the radio is put into Setup mode. Under ideal operating conditions, the number of disconnects should be **0**. One or more disconnects may indicate a weak link, the presence of severe interference problems or loss of power to any of the radios in the link.

**Note:** In Tool Suite, the disconnect information is available in the Summary View in the Network Diagnostics application.

## Radio Temperature

The **Radio Temperature** value is the current operating temperature of the transceiver in degrees Celsius. For proper operation, a FreeWave transceiver must be in the temperature range of  $-40^{\circ}$  to  $+75^{\circ}$  C. Some of the transceivers are only tested to  $0^{\circ}$  C. See the transceiver specifications later in this document for details.

## Rate %

The **Rate %** measures the percentage of data packets that were successfully transmitted from the Master to the Slave on the first attempt. A number of **75** or higher indicates a robust link that provides very good performance even at high data transmission rates. A number of **15** or lower indicates a weak or marginal link

that provides lower data throughput. A **Rate %** of **100%** provides approximately 100 KBaud of bandwidth with an **RF Data Rate** setting of **3** and approximately 150 KBaud of bandwidth with an **RF Data Rate** of **2**. These numbers are reduced approximately 50% if one or more Repeaters are in the network.

## Signal Level

The **Signal Level** indicates the level of received signal at this transceiver and at each of the Repeaters in the link. For each of these, the signal source is the transceiver that transmits to it. The number is an average of the received signal levels measured at each frequency in the transceiver's frequency hop table.



The individual measurement values at each frequency hop channel are shown in the frequency table. If you are viewing statistics in the terminal interface, press **Enter** when the Radio Statistics menu displays to view the frequency table.

For a reliable link, the margin should be at least 26 dB. Low average signal levels can often be corrected with higher gain antennas, better antenna placement and/or additional Repeaters.

**Note:** See the installation manual for antenna and FCC requirements.

## Transmit Current

This statistic is not valid in the MM2 transceivers.

The **Transmit Current** measures the current draw of the transmitter in milliamps (mA). See the transceiver specifications for typical values.

---

## Chapter 7: Troubleshooting

---

If you are experiencing trouble with your network, use the following to initially troubleshoot and help identify the problem with the network or a radio within it:

- LEDs on the transceiver. See "Point-to-MultiPoint Operation LEDs" on page 41 and "Point-to-Point Operation LEDs" on page 58.
- Radio Settings
- RF Quality

Use the following flow chart and the troubleshooting list in this chapter to walk through basic checks to help diagnose the issue. If you need assistance, contact FreeWave Technical Support.



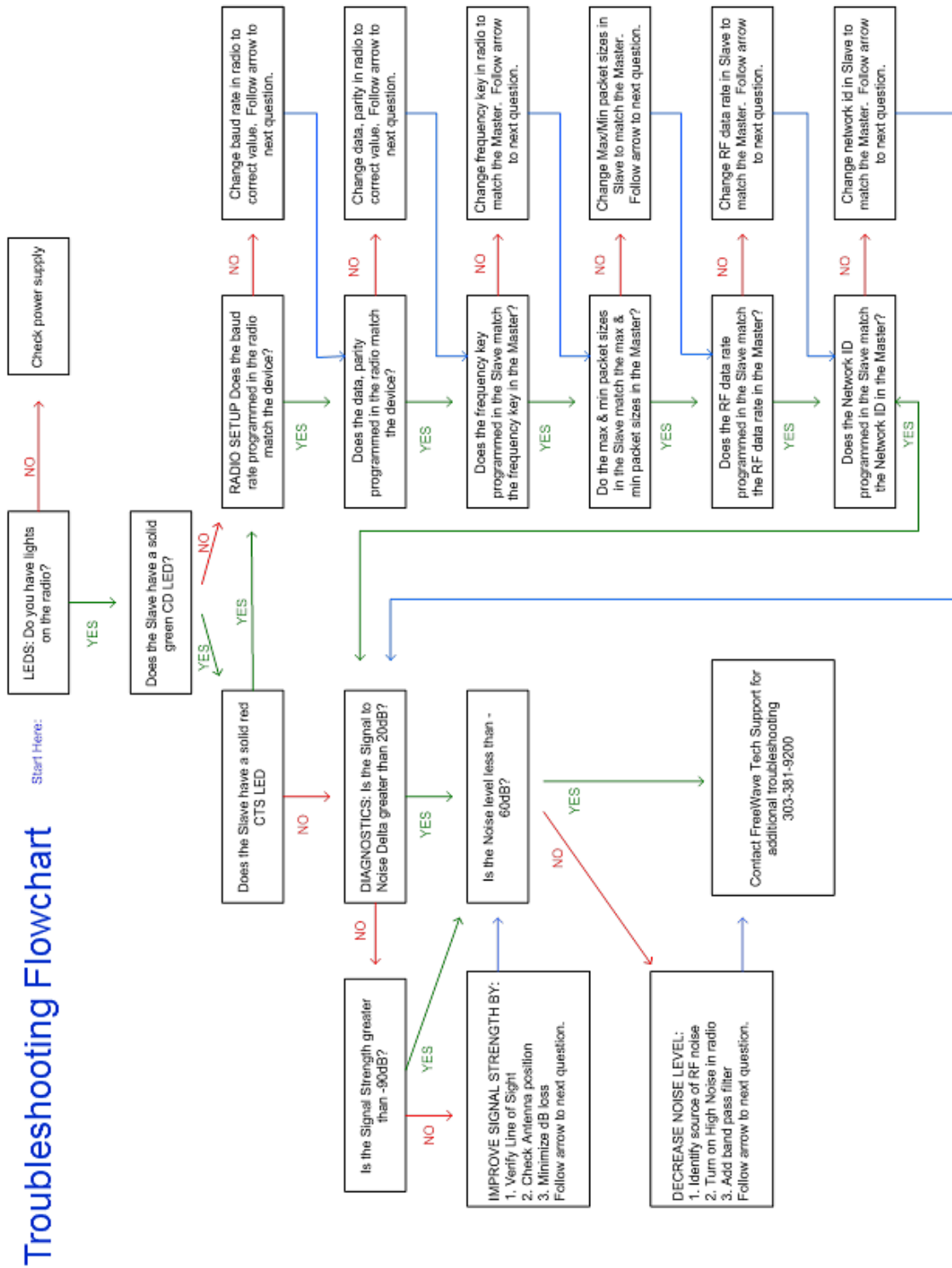











# Troubleshooting Flowchart



## Troubleshooting

**My radio does not stay in Setup mode and I am not able to program it through the diagnostics port. when I try to place the radio into Setup mode, all three LEDs flash green, and then go back to their previous state.**

Additional symptoms of this problem include:

	Carrier Detect (CD)	Transmit (Tx)	Clear to Send (CTS)
MultiPoint Master	Solid red bright 	Solid red dim 	Off 
MultiPoint Slave (unlinked)	Solid red bright 	Off 	Blinking red 
MultiPoint Slave (linked)	Solid green 	Off 	Solid red bright 
Point-to-Point Master (unlinked)	Solid red bright 	Solid red dim 	Solid red bright 
Point-to-Point Master or Slave	Solid green 	Intermittent flash red 	Intermittent flash red 

Two scenarios could be causing the radio to not enter Setup mode.

The radio is wired for RS485 and Pins 5 and 7 on a board level radio, or Pins 2 and 3 on an enclosed radio (or one with a DB9 connector) are shorted together.

1. Separate the wires and place the radio into Setup.
2. Change the **Setup Port** parameter in the Baud Rate tab to **Diagnostic Only**.

If there is a data source (PLC, RTU, PC, or Terminal Server) connected to the data port data is coming into the data port while you are trying to access Setup through the diagnostics port.

1. Disconnect the data source and place the radio into Setup.
2. Change **Setup Port** parameter in the Baud Rate tab to **Diagnostic Only**.

**My transceivers are linked, but I cannot pass data.**

Verify that the **Baud Rate** and **Data Parity** settings match between devices.

**We recently had a bad storm with lots of lightning and my transceiver has not worked since. I have replaced the transceiver but it still does not link.**

Verify that the coax cable or antenna were not damaged in the storm.

**I have a new network. My radios are linked but I am not able to pass data. Gas Company X has had a FreeWave network out here in the same area for a long time and they are not having issues. What is wrong?**

Your network is likely using the default settings for **Frequency Key**, **Network IDs**, **Minimum Packet Size**, and **Maximum Packet Size**. Refer to the user manual for the transceiver you added and change your settings from the default settings.

**Most of my sites report in and I can poll, but I cannot poll any of the Slaves that talk back to Repeater 2.**

Repeater 2 is experiencing high noise.

**My network has been running flawlessly for the last 2 years. Now, all of a sudden, I have a group of Slaves that I cannot poll.**

A Parallel Repeater has been added/changed in the network and has the same frequency settings and is now interfering with the other Repeater. Program the new Repeater with a different set of parameters.

**My network keeps locking up. If I cycle power on the Master, the network is restored and I can poll again until the next time the network locks up.**

There is a "chatty" Slave in the network. The Slave is not getting acknowledgement of data it sends to the Master and it keeps trying to resend data to the Master locking out all other communications to the Master. This is typically caused by a bad signal from the Slave to the Master. Verify line of sight, antenna direction, and noise levels at the Slave.

**I installed a new Slave in my network, but I cannot get it to link. The CD light is solid red and the CTS light is blinking red.**

LOS (Line of Sight) issue or settings issue.

**I have a site that used to perform flawlessly. Now I cannot reliably get data from the RTU at this site.**

Antenna reflected power causing problem. Reflected power may be caused by defects or damage in the antenna, cabling, connections, etc. Verify that the cabling, connectors, and the antenna are connected correctly and have not sustained any damage.

**When I connect directly to my RTU I am able to poll data successfully. When I add in the transceivers, I cannot get any data from my poll.**

Baud rate above 38,400 may need flow control line connected.

**My Master is receiving odd or incorrect data after a poll request.**

Several scenarios can cause radios in your network to send odd or incorrect data back to the Master.

FGR2 radios running firmware versions prior to 8.74 have a known issue in RS485 mode that echoes data back to the Master.

1. From within Tool Suite, save a network diagnostic file for your network.
2. Review the file to find any radios that are running firmware versions older than 8.74.
3. Upgrade those radios to the latest version of firmware available. For more information, see "Upgrading Transceivers to the Latest Firmware" on page 16.

For more information about using Tool Suite, see the *Tool Suite User Manual* available on the *User Manual and System Tools* CD or by selecting **File > Help** in the Tool Suite software.

There is a serial interface mismatch between the site, the device, or the radio.

1. From within Tool Suite, save a network diagnostic file for your network.
2. Scan the file for serial radios whose **Serial Interface** parameter is set to **RS232**.
3. For the RS232 radios, look at the Data TX information in the summary view for any radio that has an excessively high Data TX.

You are looking for one or more sites that increase the data count by the number of bytes contained in the poll request. For example, if a poll is 64 bytes, the data poll increases by 64 bytes after the poll.

4. The sites you identify may be configured as RS232, but wired as RS485. Send a technician to the site to verify the wiring.
5. If the site is wired for RS485 and the device connected to the radio is an RS485 device, correct the following parameter settings in the Baud Rate tab and send the new settings to the radio:
  - **Serial Interface** - Set to **RS485** .
  - **Setup Port** - Set to **Diagnostics Only**.
  - **Modbus RTU** - Set to **1**.
  - **Turn Off Delay** - Set to **4**.

If the site is wired for RS485 and device connected requires RS232, correct the wiring from the radio to the device.

- Pin 5 on the FreeWave radio to device RX.
- Pin 7 on the FreeWave radio to device TX.
- Pin 6 on the FreeWave radio to device signal ground.

# Chapter 8: Additional Transceiver Information

This section contains additional important information about the FreeWave transceivers described in this manual.

- Connector pin assignments
- Factory default settings
- Specifications
- Mechanical drawings

## MM2-T/MM2-LV-T Board-Level Pinout

J1 - 14 pin, 2.00 mm centers, Samtec TMM series, TMM-107-01-G-D-SM-option

Mates with Samtec CLT, SMM, MMS, SQT, ESQT, SQW, TLE, TCSD, TLSD series.

**Note:** See the drawing below for identification of pin numbers.

Pin	Input/Output	Description	Label	Notes
1	Input	Power	B+	
2	Input	Reset	Interrupt	Active Low, 100 $\mu$ s pulse
3	Input	Data Terminal Ready	DTR	TTL <sup>2</sup>
4	Ground	Ground	GND	
5	Output	Transmitted Data	TXD	0 to 3.3 V TTL <sup>1</sup>
6	Ground	Ground	GND	
7	input	Received Data	RXD	TTL <sup>2</sup>
8	Output	Carrier Detect	CD	0 to 3.3 V TTL <sup>1</sup>

Pin	Input/Output	Description	Label	Notes
9	Input	Request To Send	RTS	TTL <sup>2</sup>
10	Output	Clear To Send	CTS	0 to 3.3 V TTL <sup>1</sup>
11	Input	Diagnostic Received Data	Diag RX	TTL <sup>3</sup>
12	Output	Diagnostic Transmitted Data	Diag TX	0 to 3.3 V TTL <sup>1</sup>
13	Ground	Ground	GND	
14	Output	Baud Clock	Baud Clock	

1 - 3.3 V output assumes greater than 3.3 V input voltage. At 3 V input voltage, signal will be 0 to 3 V TTL.

2 - 0 to 5 V TTL, 330  $\Omega$  resistor in series.

3 - 0 to 5 V TTL

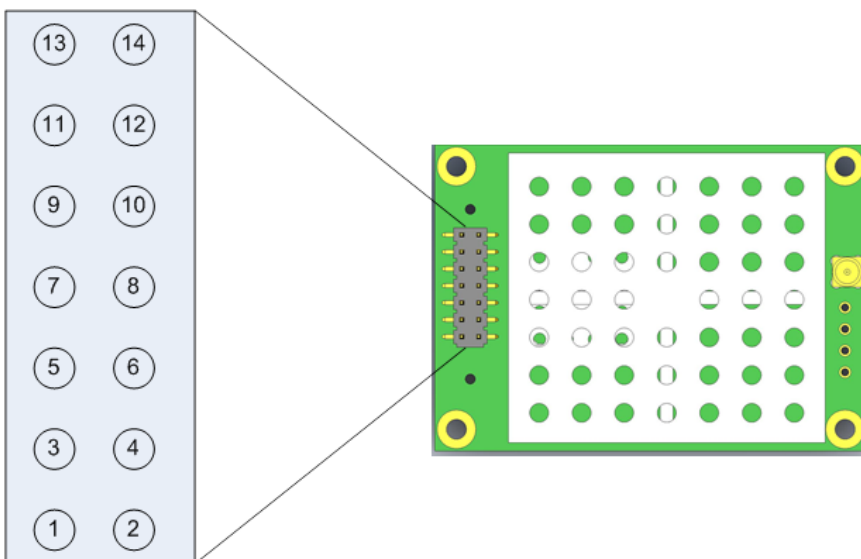

## MM2-MR-R/MM2-MR-T Board-Level Pinout

The RF board-level transceivers are available in both TTL and RS232 versions.

The TTL versions use reverse polarity from standard RS232 at 0 to 5 Volt levels. All pin descriptions and pin numbering are the same as the RS232 version. The RS232 versions use standard RS232 polarity and voltage levels for all of the RS232 signal lines (DTR, Transmit Data, Receive Data, Carrier Detect, RTS, and Clear to Send) and TTL standard polarity and voltage level for the Interrupt pin.

Pin 1: B+ Power input.

Pin 2: Interrupt (INT) – Input – A 0 Volt level on this pin switches the radio into Setup mode.

Pin 1 on the board-level transceiver is the pin farthest from the three LEDs and pin 10 is closest to the LEDs.



Pin	Assignment	Signal	Color on ACS3610xx cable
1	B+ input	Power	Red
2	Interrupt (temporarily ground to invoke menu)	Input	Brown
3	Data Terminal Ready (DTR)	Input	Orange
4	Ground		Black
5	Transmit Data (TXD)	Output	Yellow
6	Ground		Black
7	Receive Data (RXD)	Input	Green
8	Carrier Detect (DCD)	Output	Blue
9	Request to Send (RTS)	Input	Violet (purple)
10	Clear to Send (CTS)	Output	Gray

# MM2-T Model Specifications

The following specifications apply to the MM2-T, MM2-T-U, MM2-T-A1, and MM2-T-A2 models.

Specifications may change at any time without notice. For the most up-to-date specifications information, see the product's data sheet available at [www.freewave.com](http://www.freewave.com).

Specification									
Frequency	902 to 928 MHz (FHSS) (DTS)								
Transmitter									
Output power	10 mW to 1 W , 1.5W* (*Military & export versions only)								
Range	60 miles with clear line of sight								
Modulation	2 level GFSK								
RF Data Rate	Selectable speeds, 115.2 or 153.6 kbps								
Occupied bandwidth	230 kHz								
Hopping Patterns	15 per band, 105 total, user selectable								
Hopping Channels	50 to 112, user selectable								
Frequency Zones	16 zones								
RF Connector	MMCX (Straight)								
Receiver									
Sensitivity	-108 dBm at 115.2 kbps for 10 <sup>-4</sup> bit error rate -103 dBm at 153.6 kbps for 10 <sup>-4</sup> bit error rate								
IF Selectivity	40 dB at fc ± 230 kHz								
Dynamic Range	+10 dBm 3 <sup>rd</sup> Order Intercept Point at Input Connector								
Data Transmission									
Error detection	32 Bit CRC, retransmit on error								
Data encryption	Proprietary Spread Spectrum Technology								
Data Interface	1200 bps to 230.4 Kbps								
Data Connector	Straight 14-pin dual row header 2.0 mm spacing								
Data Throughput	115.2 kbps								
Power Requirements									
Operating Voltage	(± 5%) 5.0 VDC								
Typical Current (mA)	<table border="1"> <thead> <tr> <th>Mode</th> <th>+5 VDC</th> </tr> </thead> <tbody> <tr> <td>Transmit</td> <td>635</td> </tr> <tr> <td>Receive</td> <td>135</td> </tr> <tr> <td>Idle</td> <td>19</td> </tr> </tbody> </table>	Mode	+5 VDC	Transmit	635	Receive	135	Idle	19
Mode	+5 VDC								
Transmit	635								
Receive	135								
Idle	19								
Specification									
	<table border="1"> <thead> <tr> <th>Sleep</th> <th>6</th> </tr> </thead> </table>	Sleep	6						
Sleep	6								
General Information									
Operating Temperature Range	-40° C to +85° C (-40° F to 185° F)								
Dimensions	50.8 mm L x 36 mm W x 9.6 mm H (2" L x 1.4" W x 0.38" H)								
Weight	14 g (0.49 oz)								
Humidity	0 to 95% non-condensing								

This section contains additional important information about the FreeWave transceivers described in this manual.

- Operational RS422 and RS485 information
- Connector pin assignments
- Factory default settings
- Specifications
- Mechanical drawings

## Operational RS422 and RS485 Information

For RS422 and RS485, the FreeWave transceiver can drive 32 standard unit loads and loads the bus with only 1/8 unit load. This means you can tie up to 256 devices on the bus if all of the line receivers have 1/8 unit load.

RS422 is used for 4-wire or full duplex communication with one Master and multiple Slaves. The FreeWave Master transceiver keeps the line driver asserted at all times. The maximum line length is 4,000 feet using 2, 120 ohm twisted pair cables with a 5th wire for data common.

RS485 full duplex using 4 wire plus common is the same as RS422, except the system can have multiple Masters on the bus.

When setting the transceiver to RS485, enable Modbus and set **Master Packet Repeat** to **3** in the transceiver(s) that will use RS485. Also set **Turn Off Delay** to **4**.

**RS422 Full Duplex Pin-Outs**

Function	DB-9 Pin Number
RX+	8
RX-	4
TX+	7
TX-	1
Signal Ground	5

**RS485 Half Duplex Pin-Outs**

Function	DB-9 Pin Number
D+	8
D-	4
Signal Ground	5

**RS232 Pin Assignments (DB-9)**

Pin		Assignment	Signal	Definition
1	CD	Carrier Detect	Output	Used to show an RF connection between transceivers.
2	TX	Transmit Data	Output	Used to transmit data bits serially from the transceivers to the system device.
3	RX	Receive Data	Input	Used to receive data bits serially from the system device connected to the transceivers.
4	DTR	Data Terminal Ready	Input	Used only in transceivers in Point-to-Point Slave/Master switchable mode or for DTR Connect.
5	GND	Ground		Signal return for all signal lines shared with Pin 9.
6	DSR	Data Set Ready	Output	Always high when the radio is powered from the 2.5 mm power connector. Indicated power is on to the radio. Also, this pin can be used for +12 Volts when powering the transceivers directly through the RS232 port. <b>Note:</b> This is not used on the OEM module.
7	RTS	Request to Send	Input	The transceiver does not recognize RTS for flow control. RTS is used as a control line in RTS/CTS mode.

---

Pin		Assignment	Signal	Definition
8	CTS	Clear to Send	Output	This signal is used to tell the system device connected to the transceiver that the transceiver is ready to receive data. When asserted, the transceiver will accept data, when de-asserted the transceiver does not accept data. This should always be used for data rates above 38.4KB or a risk of lost data may occur if an RF link is not very robust.
9	GND	Ground		Signal return for all signal lines shared with Pin 5.

## 900 MHz Transceiver Specifications

Specifications may change at any time without notice. For the most up-to-date specifications information, see the product's data sheet available at [www.freewave.com](http://www.freewave.com).

Specification																					
Frequency	902 to 928 MHz																				
<b>Transmitter</b>																					
Output Power	5 mW to 1 W (+30 dBm) See RF transmit power settings, p. 1.																				
Range	60 miles Line Of Sight, 0 dB antenna gain																				
Modulation	2 level GFSK, 115.2 Kbps or 153.6 Kbps																				
Spreading Method	Frequency hopping																				
Occupied bandwidth @ 60dB	230 kHz																				
Channel Spacing	230 kHz																				
<b>Receiver</b>																					
Sensitivity	-109 dBm at $10^{-4}$ bit error rate -107 dBm at $10^{-6}$ bit error rate																				
Selectivity	-20 dB at $f_c \pm 115$ kHz -60 dB at $f_c \pm 145$ kHz																				
System gain	140 dB																				
<b>Data Transmission</b>																					
Data rate	115.2 kbps sustained throughput* 57.6 kbps sustained throughput* with Repeaters.																				
Error detection	32 Bit CRC, retransmit on error																				
Data encryption	Substitution, dynamic key																				
Max link throughput	115.2 KBaud																				
Data interface	RS232/RS485 1200 Baud to 230.4 KBaud, async, full duplex TTL (RF board level only)																				
<b>Power Requirements</b>																					
Operating Voltage	+6.0 to +30.0 VDC**																				
Current	<table border="1"> <thead> <tr> <th>Mode</th> <th>+6.0 VDC</th> <th>+12 VDC</th> <th>+30 VDC</th> </tr> </thead> <tbody> <tr> <td><b>Transmit</b></td> <td>1 A</td> <td>500 mA</td> <td>200 mA</td> </tr> <tr> <td><b>Receive</b></td> <td>140 mA</td> <td>75 mA</td> <td>55 mA</td> </tr> <tr> <td><b>Idle</b></td> <td>37 mA</td> <td>21 mA</td> <td>16 mA</td> </tr> <tr> <td><b>Sleep</b></td> <td>12 mA</td> <td>6 mA</td> <td>5 mA</td> </tr> </tbody> </table> <p>Transmit is at 1 W power at 100% duty cycle</p>	Mode	+6.0 VDC	+12 VDC	+30 VDC	<b>Transmit</b>	1 A	500 mA	200 mA	<b>Receive</b>	140 mA	75 mA	55 mA	<b>Idle</b>	37 mA	21 mA	16 mA	<b>Sleep</b>	12 mA	6 mA	5 mA
Mode	+6.0 VDC	+12 VDC	+30 VDC																		
<b>Transmit</b>	1 A	500 mA	200 mA																		
<b>Receive</b>	140 mA	75 mA	55 mA																		
<b>Idle</b>	37 mA	21 mA	16 mA																		
<b>Sleep</b>	12 mA	6 mA	5 mA																		

Specification	
Operating environment	-40° C- +75° C, 0 to 95% humidity non-condensing

\* At 100% receive success rate. RF data rate setting of 2.

\*\* FGR2 transceivers are UL approved for use between +6.0 to +30.0 VDC. However, for optimal performance, FreeWave recommends using a power supply between +7.5 VDC and +30 VDC.

	FGR2-C	FGR2-CE
Data Port	RS232/485/422, DB-9	RS232/485/422, DB-9
Enclosure	Bare board	Extruded aluminum
Dimensions	14 mm H x 52 mm W x 89 mm L	43 mm H x 57 mm W x 98 mm L
Weight	46 grams	228 grams
Power requirements	+7.5 to +30.0 VDC*	<ul style="list-style-type: none"> <li>+7.5 to +30.0 VDC*</li> <li>AC wall adapter provided</li> <li>May be powered through pin 6 of DB9 connector.</li> </ul>
Antenna	MMCX female connector. External antenna required.	TNC type female connector. External antenna required.
FCC Identifier	KNY-42182112519	KNY-42182112519
IC Identifier	2329B-FGR2	2329B-FGR2

\* FGR2 transceivers are UL approved for use between +6.0 to +30.0 VDC. However, for optimal performance, FreeWave recommends using a power supply between +7.5 VDC and +30 VDC.

	FGR2-多串口	FGR2-15瓦
Data Port	RS232/485/422, DB-9	RS232/485/422, DB-9
Enclosure	Extruded aluminum	Extruded aluminum
Dimensions	43 mm H x 86 mm W x 98 mm L	62 mm H x 115 mm W x 150 mm L
Weight	300grams	900 grams
Power requirements	+7.5 to +30.0 VDC*	<ul style="list-style-type: none"> <li>+10.5 to +16 VDC*</li> <li>AC wall adapter provided</li> <li>May be powered through pin 6 of DB9 connector.</li> </ul>
Antenna	TNC type female connector. External antenna required.	TNC type female connector. External antenna required.
FCC Identifier	KNY-42182112519	KNY-42182112519
IC Identifier	2329B-FGR2	2329B-FGR2

## MM2-LV-T Model Specifications

The following specifications apply to the MM2-LV-T, MM2-LV-T-U, MM2-LV-T-A1, and MM2-LV-T-A2 models. Specifications may change at any time without notice. For the most up-to-date specifications information, see the product's data sheet available at [www.freewave.com](http://www.freewave.com).

Specification					
Frequency	902 to 928 MHz (FHSS) (DTS)				
<b>Transmitter</b>					
Output power	10 mW to 1 W, 1.5W* (*Military & export versions only)				
Range	60 miles with clear line of sight				
Modulation	2 level GFSK				
RF Data Rate	Selectable speeds, 115.2 or 153.6 kbps				
Occupied bandwidth	230 kHz				
Hopping Patterns	15 per band, 105 total, user selectable				
Hopping Channels	50 to 112, user selectable				
Frequency Zones	16 zones				
RF Connector	MMCX (Straight)				
<b>Receiver</b>					
Sensitivity	-108 dBm at 115.2 kbps for $10^{-4}$ bit error rate -103 dBm at 153.6 kbps for $10^{-4}$ bit error rate				
IF Selectivity	40 dB at $f_c \pm 230$ kHz				
RF Selectivity	50 dB at 896 MHz, 935 MHz				
Dynamic Range	+10 dBm 3 <sup>rd</sup> Order Intercept Point at Input Connector				
<b>Data Transmission</b>					
Error detection	32 Bit CRC, retransmit on error				
Data encryption	Proprietary Spread Spectrum Technology				
Data Interface	1200 bps to 230.4 Kbps				
Data Connector	Straight 14-pin dual row header 2.0 mm spacing				
Data Throughput	115.2 kbps				
<b>Power Requirements</b>					
Operating Voltage	( $\pm 5\%$ ) 3.5 VDC				
Typical Current (mA)	<table> <tr> <td><b>Mode</b></td> <td><b>+3.5 VDC</b></td> </tr> <tr> <td><b>Transmit</b></td> <td>760</td> </tr> </table>	<b>Mode</b>	<b>+3.5 VDC</b>	<b>Transmit</b>	760
<b>Mode</b>	<b>+3.5 VDC</b>				
<b>Transmit</b>	760				

---

Specification	
	<b>Receive</b> 125 <b>Idle</b> 38 <b>Sleep</b> 8
General Information	
Operating Temperature Range	-40° C to +85° C (-40° F to 185° F)
Dimensions	50.8 mm L x 36 mm W x 9.6 mm H (2" L x 1.4" W x 0.38" H)
Weight	14 g (0.49 oz)
Humidity	0 to 95% non-condensing

## MM2-R Model Specifications

The following specifications apply to the MM2-MR-R, MM2-MR-R-U, MM2-MR-R-A1, and MM2-MR-R-A2, MM2-MR-T, and MM2-MR-T-U models

Specifications may change at any time without notice. For the most up-to-date specifications information, see the product's data sheet available at [www.freewave.com](http://www.freewave.com).

Specification									
Frequency	902 to 928 MHz (FHSS) (DTS)								
<b>Transmitter</b>									
Output power	10 mW to 1 W								
Range	60 miles with clear line of sight								
Modulation	2 level GFSK								
RF Data Rate	Selectable speeds, 115.2 or 153.6 kbps								
Occupied bandwidth	230 kHz								
Hopping Patterns	15 per band, 105 total, user selectable								
Hopping Channels	50 to 112, user selectable								
Frequency Zones	16 zones								
RF Connector	MMCX (Straight)								
<b>Receiver</b>									
Sensitivity	-107 dBm at 115.2 kbps for $10^{-4}$ bit error rate -102 dBm at 153.6 kbps for $10^{-4}$ bit error rate								
IF Selectivity	40 dB at $f_c \pm 230$ kHz								
RF Selectivity	50 dB at 896 MHz, 935 MHz								
Dynamic Range	+10 dBm 3 <sup>rd</sup> Order Intercept Point at Input Connector								
<b>Data Transmission</b>									
Error detection	32 Bit CRC, retransmit on error								
Data encryption	Proprietary Spread Spectrum Technology								
Data Interface	1200 bps to 230.4 Kbps								
Data Connector	Straight 14-pin dual row header 2.0 mm spacing								
Data Throughput	115.2 kbps								
<b>Power Requirements</b>									
Operating Voltage	+6.5 VDC to +30.0 VDC								
Typical Current	<table border="1"> <thead> <tr> <th>Mode</th> <th>+6.5 VDC</th> <th>+12.0 VDC</th> <th>+30.0 VDC</th> </tr> </thead> <tbody> <tr> <td></td> <td></td> <td></td> <td></td> </tr> </tbody> </table>	Mode	+6.5 VDC	+12.0 VDC	+30.0 VDC				
Mode	+6.5 VDC	+12.0 VDC	+30.0 VDC						

Specification																	
	<table> <tr> <td><b>Transmit</b></td> <td>1 A</td> <td>500 mA</td> <td>200 mA</td> </tr> <tr> <td><b>Receive</b></td> <td>152 mA</td> <td>86 mA</td> <td>43 mA</td> </tr> <tr> <td><b>Idle</b></td> <td>40 mA</td> <td>21 mA</td> <td>12 mA</td> </tr> <tr> <td><b>Sleep</b></td> <td>8 mA</td> <td>6 mA</td> <td>3 mA</td> </tr> </table>	<b>Transmit</b>	1 A	500 mA	200 mA	<b>Receive</b>	152 mA	86 mA	43 mA	<b>Idle</b>	40 mA	21 mA	12 mA	<b>Sleep</b>	8 mA	6 mA	3 mA
<b>Transmit</b>	1 A	500 mA	200 mA														
<b>Receive</b>	152 mA	86 mA	43 mA														
<b>Idle</b>	40 mA	21 mA	12 mA														
<b>Sleep</b>	8 mA	6 mA	3 mA														
General Information																	
Operating Temperature Range	-40° C to +85° C (-40° F to 185° F)																
Dimensions	70 mm L x 62 mm W x 9.6 mm H (2.75" L x 2.4" W x 0.40" H)																
Weight	38 g																
Humidity	0 to 95% non-condensing																

## MM2-T/MM2-LV-T Mechanical Drawing

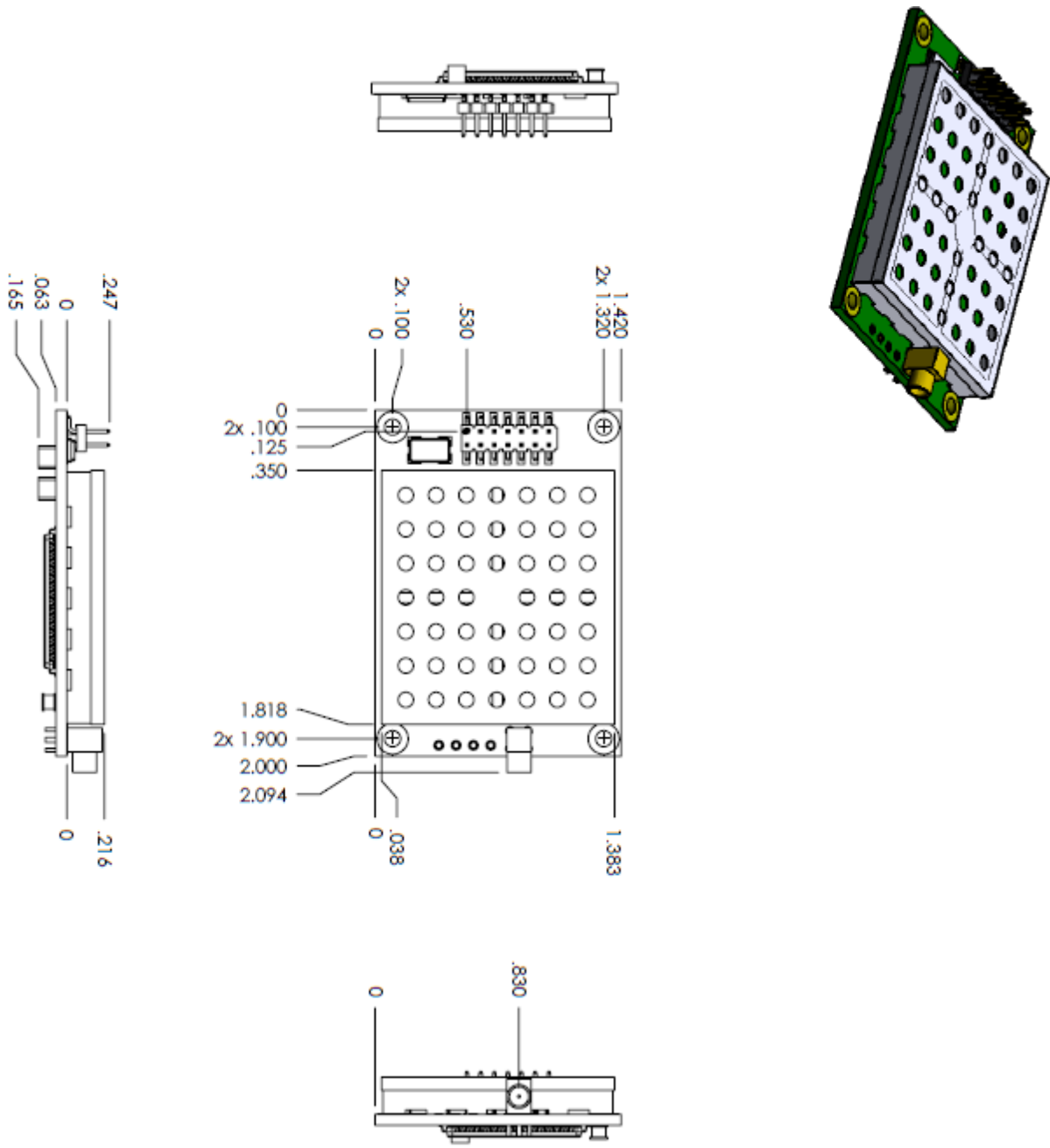

## MM2-MR Mechanical Drawing

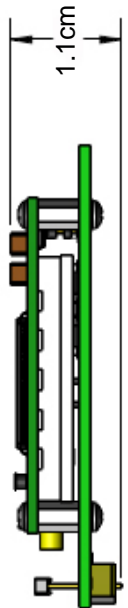
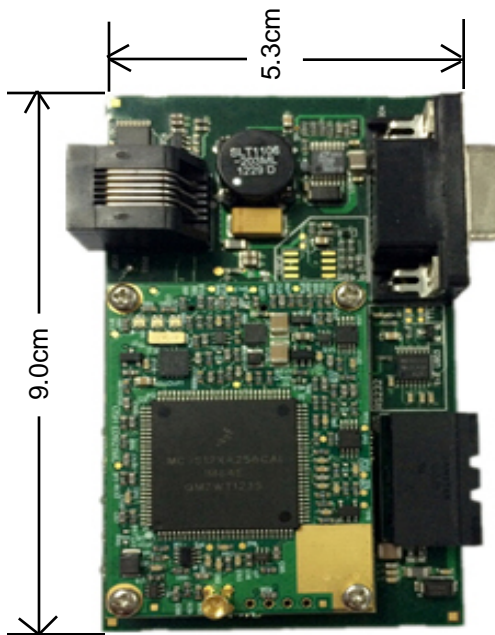
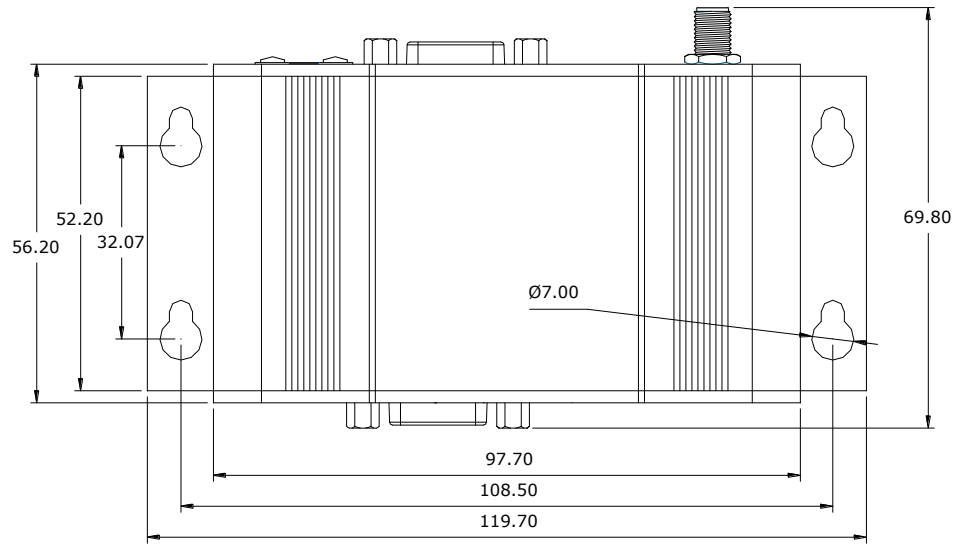

## Factory Default Settings

FreeWave serial transceivers are shipped from the factory with the following default settings:

Operation Mode	Default	MultiPoint Parameters	Default
Point-to-Point Slave	1	(0) NUMBER OF REPEATERS	1
<b>Set Baud Rate</b>	<b>Default</b>	(1) MASTER PACKET REPEAT	2
Baud Rate	115200	(2) MAX SLAVE RETRY	9
(A) Data Parity	0	(3) RETRY ODDS	9
(B) Modbus RTU	0	(4) DTR CONNECT	0
(C) RS232/485	0	(5) REPEATER FREQUENCY	0
(D) Setup Port	3	(6) NETWORK ID	255
(E) TurnOffDelay/OnDelay	0/0	(7) RESERVED	-
(F) Flow Control	0	(8) MULTI MASTER SYNC	0
<b>Radio Parameters</b>	<b>Default</b>	(9) 1 PPS ENABLE DELAY	255
(0) FREQ KEY	5	(A) SLAVE/REPEATER	0
(0) HOP TABLE VERSION	0	(B) DIAGNOSTICS	0
(1) HOP TABLE SIZE	112	(C) SUBNET ID	"Disabled"
(2) HOP FREQ OFFSET	0	Rx ID	F
(3) Frequency Zone	All 1s (Enabled)	Tx ID	F
(4) Government Rules	0	(D) RADIO ID	Not Set
(1) MAX PACKET SIZE	8	(E) Local Access	0
(2) MIN PACKET SIZE	9	(G) Radio Name	"blank"
(3) XMT RATE	1		
(4) RF DATA RATE	3		
(5) RF XMT POWER	10		
(6) SLAVE SECURITY	0		
(7) RTS TOCTS	0		
(8) RETRY TIMEOUT	255		
(9) LOW POWER MODE	0		
(A) High Noise	0		
(B) MCU Speed	0		
(C) Remote LED	0		

---

## Appendix A: Firmware Updates

---

The sections below describe the updates and known limitations in each firmware version for the FGR2 transceiver models, as of this document's release. The most recent version is listed first. The latest firmware versions are available on the FreeWave Web site at [www.freewave.com](http://www.freewave.com). You can also view the latest firmware available for most models in Tool Suite.

### Version v10.6.6

**Release Date: October 2012**

**Note:** If you upgrade from firmware 8.77 or 8.78 to firmware v10.6.6 and experience issues or inconsistent results, contact FreeWave Technical Support at 303.381.9200 or by email at [moreinfo@freewave.com](mailto:moreinfo@freewave.com).

Additions and Changes:

- Updated firmware version to use the vX.X.X format.
- Added AES 128, 192, and 256 encryption capability. AES functionality is enabled at the factory. To upgrade an existing transceiver to use the AES functionality, contact FreeWave Technical Support.

You must set AES options using the terminal interface, as Tool Suite versions 2.8.7.5 and before do not include AES.

- Removed the Ultra Low Power Mode feature.

Known Limitations and Work Arounds:

- In the Network Diagnostics application within Tool Suite, the transceivers report having the incorrect firmware version installed.
- In the Operation Mode tab in Tool Suite (Modem Mode menu tab in the terminal interface), Ethernet parameters display. These options do not apply to this radio.

- When the **Use Break to Access Setup** setting is set to use the transceiver's current baud rate (a setting only available through the terminal interface), the Diagnostic port's baud rate does not set to the default or the **Baud Rate** setting, resulting in unreadable output. If you use this **Use Break to Access Setup** setting, use the data port for configuration.

## Version 8.78

**Release Date: December 2011**

Additions and Changes:

- **AES zeroization** - AES capability now supports zeroization, attempting to hold to NAVSO P5239, and various locks and checks against zeroized keys. (This update does not apply to FGR2 models).
- **Clear 8th data bit when set to 7 data bits** - In a case where one radio is programmed with 7 data bits, and parity enabled, the parity bit is transferred by the radios as the 8th data bit, and sent out the port on the other side. This corrupts the data. Now if the radio is set to 7 data bits, it clears the 8th data bit on serial receive.
- **Repeater un-shifts timing in OTA slot** - Repeaters shift half of their timing to ensure their transmissions lineup exactly in time with the masters (2nd layer deep). During an over the air firmware upgrade, the repeater shifted half of it's timing, but did not unshift the timing. This could build into a timing problem causing drop of link on sufficient missed packets.
- **Ultra Low Power Mode - ULPM Enable and ULPM Sleep** parameters now available in the Transmission Characteristics settings. For more information about **Ultra Low Power Mode**, see the Parameter Reference chapter in this manual.

## Version 8.77

**Release Date: May 2011**

Additions and Changes:

- Added support for mirror bits and multi-band master sync.
- You can now select Mirrored Bit Master or Mirrored Bit Slave as an operation mode.

Known Limitations and Work Arounds:

- None.

## Version 8.73

**Release Date: October 2009**

Additions and Changes:

- None

Issues Resolved:

- RS485 Protocol fixed.
- Use Break Command to Enter Setup function fixed.

- Grand Master mode (for Multi-Master Sync) feature fixed.

Known Limitations and Work Arounds:

- None

## **Version 8.71**

**Release Date: August 2009**

Additions and Changes:

- Improved efficiency and reliability of writing TDMA settings to memory.
- Improved efficiency and reliability of writing Diagnostics settings to memory.

Known Limitations and Work Arounds:

- None

## **Version 8.70**

**Release Date: March 2009**

Additions and Changes:

- Mirror back-end changes.

Known Limitations and Work Arounds:

- None

## **Version 8.69**

**Release Date: October 2008**

Additions and Changes:

- None

Issues Resolved:

- Link acquisition issue corrected.

Known Limitations and Work Arounds:

- None

## **Version 8.68 (Initial Release)**

**Release Date: June 2008**

Known Limitations and Work Arounds:

- None

# FGR2 ( MM2 ) 快速设置步骤

## 一、进入设置

首先用诊断线连接 FGR2(MM2) 到电脑的串口，然后给 FGR2(MM2) 加电。

### 方式 A、使用超级终端，设置步骤如下：

1、在 XP 系统中打开超级终端：“开始→所有程序→附件→通讯→超终端” 在名称文本框中，键入一个描述性的名称（如：19200）。



2、单击“确定”按钮，进入下面的“连接”对话框。根据自己电脑的情况，从“连接使用”下拉菜单中选择要使用的串口。设置完成后单击“确定”。

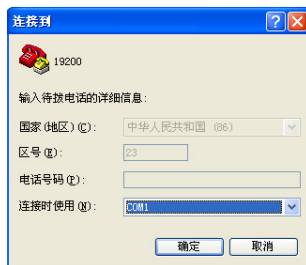

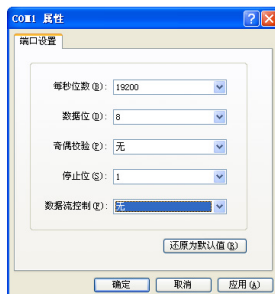

3、进入属性对话框，设置端口属性，必须设置为：19200，8N1，无流控的格式。单击确定后，进入超级终端对话框（如下图）。

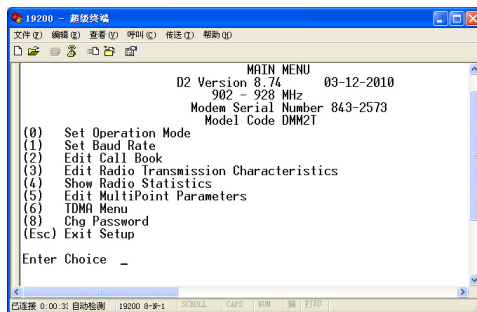

4、在光标处，键入“m”后，按回车键。进入 FGR2(MM2) 电台的设置菜单（如下图），并且电台指示灯将显示为绿色。



### 方式 B、使用 Tool Suite，设置步骤如下：

1、首先安装“FreeWave Tool Suite”设置软件，双击  打开，单击  进入设置界面。

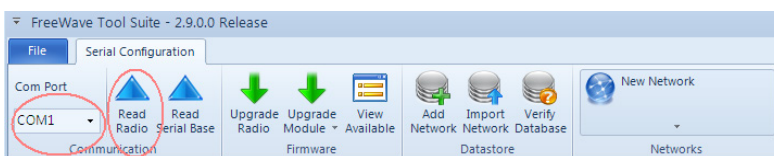

2、在“Com Port”中选择对应电脑的串口，然后单击“Read Radio”读取电台参数。

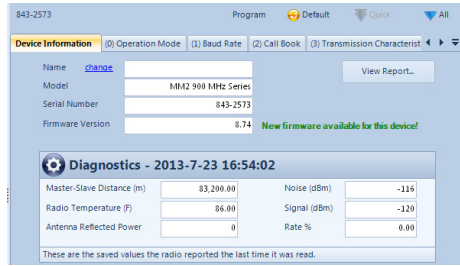

3、“Tool Suite”与“超级终端”对应图举例。

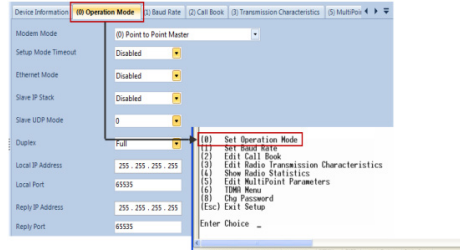

## 二、点对点通讯

选择一种登录方式，进入 FGR2(MM2) 配置界面。

- 1、必须选择电台的工作模式：（两个电台，一台选择“(0) Point to Point Master”，另一台选择“(1)Point to Point Slave”）
- 2、在“Baud Rate”菜单里，设置电台的接口速率：（从 1200-230400bps），默认数据格式：115200
- 3、编辑“Call Book”参数：主台的“Call Book”里面输入从台的序列号，从台的“Call Book”里面输入主台的序列号。（每个电台都有一个唯一的序列号）
- 4、设置“Transmission Characteristics”里面的参数（下列参数必须设置，且主台和从台的下列参数必须一致）：
  - Frequency Key: 5（默认值）
  - Max Packet Size: 9（默认值）
  - Min Packet Size: 1（默认值）
  - RF Date Rate: High（默认值）
- 5、设置完成后，按 Esc 键保存退出设置（超级终端）；单击 Quick 保存退出设置（Tool Suite）。

Point-to-Point Operation LEDs

Condition	Master			Slave			Repeater		
	Carrier Detect (CD)	Transmit (Tx)	Clear to Send (CTS)	Carrier Detect (CD)	Transmit (Tx)	Clear to Send (CTS)	Carrier Detect (CD)	Transmit (Tx)	Clear to Send (CTS)
Powered, no link	Solid red ■	Solid red ■	Solid red ■	Solid red ■	Off ■	Solid red ■	Solid red ■	Off ■	Blinking red ■
Linked, no Repeater, sending sparse data	Solid green ■	Intermittent flash red ■	Intermittent flash red ■	Solid green ■	Intermittent flash red ■	Intermittent flash red ■	n/a	n/a	n/a
Master calling Slave through Repeater	Solid red ■	Solid red dim ■	Solid red ■	Solid red ■	Off ■	Blinking red ■	Solid red ■	Off ■	Blinking red ■
Master linked to Repeater, not to Slave	Flashing orange ■	Solid red dim ■	Solid red ■	Solid red ■	Off ■	Blinking red ■	Solid red ■	Solid red dim ■	Solid red ■
Repeater linked to Slave	Solid green ■	Intermittent flash red ■	Intermittent flash red ■	Solid green ■	Intermittent flash red ■	Intermittent flash red ■	Solid green ■	Intermittent flash red ■	Intermittent flash red ■
Mode 6 - waiting for ATD command	Solid red ■	Off ■	Blinking red ■	Solid red ■	Off ■	Blinking red ■	n/a	n/a	n/a
Setup Mode	Solid green ■	Solid green ■	Solid green ■	Solid green ■	Solid green ■	Solid green ■	Solid green ■	Solid green ■	Solid green ■

## 三、点对多点通讯

选择一种登录方式，进入 FGR2(MM2) 配置界面。

- 1、必须选择电台的工作模式：（主电台，主台选择“(2) Point to MultiPoint Master”，从电台选择“(3)Point to MultiPoint Slave”）
- 2、在“Baud Rate”菜单里，设置电台的接口速率：（从 1200-230400bps），默认数据格式：115200
- 3、设置“Transmission Characteristics”里面的参数（下列参数必须设置，且主台和从台下列参数必须一致）：
  - Frequency Key: 5（默认值）
  - Max Packet Size: 9（默认值）
  - Min Packet Size: 1（默认值）
  - RF Date Rate: High（默认值）
  - Network ID: 0-4095 之间的任意一个数值（255 除外），

点对多点通讯不建议使用“Call Book”，而使用“Network ID”，且主台和从台的“Network ID”值必须设置一致。（“Network ID”在“MultiPoint Parameters”界面里，默认值为“255”，在点对多点通讯使用 Network ID 时，必须改掉。）
- 4、设置完成后，按 Esc 键保存退出设置（超级终端）；单击 Quick 保存退出设置（Tool Suite）。

### Point-to-MultiPoint Operation LEDs

Condition	Master			Slave			Repeater		
	Carrier Detect (CD)	Transmit (Tx)	Clear to Send (CTS)	Carrier Detect (CD)	Transmit (Tx)	Clear to Send (CTS)	Carrier Detect (CD)	Transmit (Tx)	Clear to Send (CTS)
Powered, not linked	Solid red bright	Solid red dim	Off	Solid red bright	Off	Blinking red	Solid red bright	Off	Blinking red
Repeater and Slave linked to Master, no data	Solid red bright	Solid red dim	Off	Solid green	Off	Solid red bright	Solid green	Solid red dim	Solid red bright
Repeater and Slave linked to Master, Master sending data to Slave	Solid red bright	Solid red dim	Off	Solid green	Off	Solid red bright	Solid green	Solid red dim	Solid red bright
Repeater and Slave linked to Master, Slave sending data to Master	Solid green RCV data or Solid red bright	Solid red dim	Intermittent flash red	Solid green	Intermittent flash red	Solid red bright	Solid green	Solid red dim	Solid red bright
Master with diagnostics program running	Solid red bright	Solid red dim	Intermittent flash red	Solid green	Intermittent flash red	Solid red bright	Solid green	Solid red dim	Solid red bright

## 四、电台常用设置参数

1、Baud Rate(接口数率) 默认：115200

可以选择：600, 1200, 2400, 4800, 9600, 19200, 38400, 57600, 76800, 115200, 230400

2、Data Parity(数据校验)：默认：0(8, N, 1), 可根据自己的需要重新设置。

3、Frequency Key(频率键值) 默认：5

从0到9和A到E选择。每一个值代表一种跳频模式。

注意：不要在选择915-928MHz和916-920MHz运行时，使用“E”键。

4、Hop Table Version(频率范围) 默认：902-928MHz

选项：902-928MHz, 全频段；915-928MHz；916-920MHz；921-928MHz；902-915MHz

Option	Data Bits	Parity	Stop Bits
0	8	None	1
1	7	Even	1
2	7	Odd	1
3	8	None	2
4	8	Even	1
5	8	Odd	1

5、RF Data Rate(空中速率) 默认：(2) High

选项：•(2)High-154kbps •(3)Normal-115.2kbps

6、Max Packet Size and Min Packet Size(最大数据包大小和最小数据包大小，单位：字节)

默认：Max:9 Min:1

Minimum Packet Size Definition		
Min Setting	Min Packet Size RF Data Rate = 2	Min Packet Size RF Data Rate = 3
0	15	8
1	21	12
2	26	16
3	31	20
4	37	24
5	42	28
6	47	32
7	53	36
8	58	40
9	63	44

Maximum Packet Size Definition with RF Data Rate of 2 for MM2-T-U, MM2-LV-T-U										
Min Setting	Max Setting									
	0	1	2	3	4	5	6	7	8	9
0	15	37	58	79	101	122	143	165	186	207
1	21	42	63	85	106	127	149	170	191	213
2	26	47	69	90	111	133	154	175	197	218
3	31	53	74	95	117	138	159	181	202	223
4	37	58	79	101	122	143	165	186	207	229
5	42	63	85	106	127	149	170	191	213	234
6	47	69	90	111	133	154	175	197	218	239
7	53	74	95	117	138	159	181	202	223	245
8	58	79	101	122	143	165	186	207	229	250
9	63	85	106	127	149	170	191	213	234	255

Maximum Packet Size Definition with RF Data Rate of 3										
Minimum Setting	Maximum Setting									
	0	1	2	3	4	5	6	7	8	9
0	8	24	40	56	72	88	104	120	136	152
1	12	28	44	60	76	92	108	124	140	156
2	16	32	48	64	80	96	112	128	144	160
3	20	36	52	68	84	100	116	132	148	164
4	24	40	56	72	88	104	120	136	152	168
5	28	44	60	76	92	108	124	140	156	172
6	32	48	64	80	96	112	128	144	160	176
7	36	52	68	84	100	116	132	148	164	180
8	40	56	72	88	104	120	136	152	168	184
9	44	60	76	92	108	124	140	156	172	188

7、Transmit Power(发射功率) 默认：10 可根据需要设置输出功率

Setting	Power (in mW) for MM2 radios
0	5
1	10
2	35
3	80
4	140
5	230
6	330
7	480
8	600
9	800
10	1000

以上只是常用的设置参数，其它更多参数及产品应用详见说明书。

# FGR2-CE 多串口电台使用说明

串口复用板总串口速率可以设置为 19200, 38400, 115200bps, 总串口可分成三个分串口通讯, 分串口分别为 COM1, COM2, COM3, 按 COM1 对 COM1, COM2 对 COM2, COM3 对 COM3 透明传输数据。分串口接口波特率支持: 9600, 19200, 38400bps, 3 个分串口波特率总和原则上要低于总串口波特率, 特别是数据量较大时。

## 设置

1、COM3 为主板设置口, 给主板加电前将短路帽插在“SET”端(正常运行时插在“RUN”端, COM3 为数据口)

2、将 COM3 连到电脑串口, 电脑运行 SSCOM3.2 程序 (或其它串口程序) 数据格式设置为: 38400, 8N1, 选字符格式显示、字符格式发送, 电台加电。

3、设置分串口波特率:

分串口波特率: 9600, 19200, 38400bps, 分别对应 1, 2, 3 三个选项, 根据实际使用的波特率, 输入波特率对应的数字, 如使用 38400bps, 输入 3。依次设置 3 个分串口的接口波特率。

【1=9600, 2=19200, 3=38400】

4、设置总串口波特率:

总串口波特率: 19200, 38400, 115200bps, 分别对应 1, 2, 3 三个选项, 根据实际使用的波特率, 输入波特率对应的数字。如使用 115200bps, 输入 3。

【1=19200, 2=38400, 3=115200】



注意: 必须一次全部设置完 3 个分串口、总串口。界面上出现 OK 字样才算设置成功, 设置完成后请按要求重启, 如果中途退出, 则此次设置无效。(设置完成后, 断电将跳线帽插在“RUN”端)

默认设置 总串口: 115200

分 1: 38400

分 2: 38400

分 3: 38400

插排引脚定义:

COM3 (RS232)  
1-----TXD  
2-----RXD  
3-----GND

COM2 (RS232)  
4-----TXD  
6-----RXD  
3-----GND

9-----VCC(DC:7-30V)  
8-----GND(电源地)



COM1(DB9母)引脚定义:  
RS232

2-----TXD  
3-----RXD  
5-----GND

RS422

7-----T+  
1-----T-  
8-----R+  
4-----R-



## Shenzhen Sinosun Technology Co., Ltd.

3A17, South Plaza Cangsong Building, Tairan Industry & Trade Zone ,  
Futian District, Shenzhen, Guangdong, China

Phone: (0086)755-83849417 Fax: (0086)755-83849434

Web: [www.sinosun.cn](http://www.sinosun.cn) E-Mail: [sales2@sinosun.cn](mailto:sales2@sinosun.cn)